

# Meridian *CDMA*

*Frequency Reference*



*User Manual*



---

# Meridian CDMA

## *Frequency Reference User Manual*

### **Preface**

Thank you for purchasing the Meridian CDMA Frequency Reference. Our goal in developing this product is to bring you a precise time and frequency reference that will quickly, easily and reliably meet or exceed your system requirements. Your new Meridian is fabricated using the highest quality materials and manufacturing processes available today, and will give you years of troublefree service.

### **About EndRun Technologies**

EndRun Technologies is dedicated to the development and refinement of the technologies required to fulfill the demanding needs of the time and frequency community.

The instruments produced by EndRun Technologies have been selected as the timing reference for a variety of industries and applications - computer networks, satellite earth stations, power utilities, test ranges, broadcast and telecommunications systems and more.

EndRun Technologies is committed to fulfilling your precision timing needs by providing the most advanced, reliable and cost-effective time and frequency equipment available in the market today.

### **Trademark Acknowledgements**

IBM-PC, Linux, NotePad, Timeserv, UNIX, Windows NT, WordStar are registered trademarks of the respective holders.

Part No. USM3025-0000-000 Revision 6  
February 2013

Copyright © EndRun Technologies 2009-2013

---

## **About This Manual**

This manual will guide you through simple installation and set up procedures.

**Introduction** – The Meridian, how it works, where to use it, its main features.

**Basic Installation** – How to connect, configure and test your Meridian.

**Console Port** – Description of the Linux console commands for use over the network and serial ports.

If you detect any inaccuracies or omissions, please inform us. EndRun Technologies cannot be held responsible for any technical or typographical errors and reserves the right to make changes to the product and manuals without prior notice.

## **Warranty**

This product, manufactured by EndRun Technologies, is warranted against defects in material and workmanship for a period of two years from date of shipment, under normal use and service. During the warranty period, EndRun Technologies will repair or replace products which prove to be defective.

For warranty service or repair, this product must be returned to EndRun Technologies. Buyer shall prepay shipping charges to send product to EndRun Technologies and EndRun Technologies shall pay shipping charges to return product to Buyer. However, if returned product proves to be operating normally (not defective) then Buyer shall pay for all shipping charges. If Buyer is located outside the U.S.A. then Buyer shall pay all duties and taxes, if any.

Products not manufactured by EndRun Technologies but included as an integral part of a system (e.g. peripherals, options) are warranted for ninety days, or longer as provided by the original equipment manufacturer, from date of shipment.

## **Limitation of Warranty**

The foregoing express warranty shall not apply to defects resulting from improper or inadequate maintenance by Buyer or User, Buyer-supplied software or interfacing, unauthorized modification or misuse, operation outside of the environmental specifications for the product, or improper site preparation or maintenance.

TO THE EXTENT PERMITTED BY LAW, THIS WARRANTY AND REMEDIES SET FORTH ABOVE ARE EXCLUSIVE AND IN LIEU OF ALL OTHER WARRANTIES, REMEDIES AND CONDITIONS WHETHER ORAL OR WRITTEN, STATUTORY, EXPRESS, OR IMPLIED. AS PERMITTED BY APPLICABLE LAW, ENDRUN SPECIFICALLY DISCLAIMS THE IMPLIED WARRANTIES OF MERCHANTABILITY OR FITNESS FOR A PARTICULAR PURPOSE.

---

## **Warranty Repair**

If you believe your equipment is in need of repair, call EndRun Technologies and ask for a customer service agent. It is important to contact us first as many problems may be resolved with a phone call. Please have the serial number of the unit and the nature of the problem available before you call. If it is determined that your equipment will require service, we will issue an RMA number. You will be asked for contact information, including your name, address, phone number and e-mail address.

Ship the unit prepaid in the original container or a container of sufficient strength and protection to EndRun Technologies. EndRun will not be responsible for damage incurred during shipping to us. Be sure the RMA number is clearly identified on the shipping container. Our policy is to repair the unit within 5 business days. If it is necessary to order parts or if other circumstances arise that require more than 5 days, an EndRun service technician will contact you.

Loaner units are not included as part of the standard warranty.

## **Repair After Warranty Expiration**

If the warranty period has expired, we offer repair services for equipment you have purchased from EndRun. Call and ask for a customer service agent. It is important to contact us first as many problems may be resolved with a phone call. Please have the serial number of the unit and the nature of the problem available before you call. If it is determined that the equipment has failed and you want EndRun to perform the repairs, we will issue you an RMA number. Ship the unit prepaid in the original container or a container of sufficient strength and protection to EndRun Technologies. EndRun will not be responsible for damage incurred during shipping to us. Customer is responsible for shipping costs to and from EndRun Technologies. Be sure the RMA number is clearly identified on the shipping container. After the equipment has been received we will evaluate the nature of the problem and contact you with the cost to repair (parts and labor) and an estimate of the time necessary to complete the work.

## **Limitation of Liability**

The remedies provided herein are Buyer's sole and exclusive remedies. EndRun Technologies shall not be liable for any direct, indirect, special, incidental or consequential damages, whether based on contract, tort or any other legal theory.

## **EndRun Contact Information**

Address: EndRun Technologies  
2270 Northpoint Parkway  
Santa Rosa, CA 95407  
U.S.A  
Phone: (707)573-8633  
Fax: (707)573-8619  
Sales: 1-877-749-3878 or (707)573-8633  
sales@endruntechnologies.com  
Support: 1-877-749-3878 or (707)573-8633  
support@endruntechnologies.com



---

# Table of Contents

Preface .....	i
About EndRun Technologies .....	i
Trademark Acknowledgements .....	i
About This Manual .....	ii
Warranty .....	ii
Limitation of Warranty .....	ii
Warranty Repair .....	iii
Repair After Warranty Expiration .....	iii
Limitation of Liability .....	iii
EndRun Contact Information .....	iii
<b>Chapter One - Introduction .....</b>	<b>1</b>
Main Features .....	1
Overview .....	1
Highly-Reliable, Modular Design .....	1
Standard Features .....	1
Secure Network Interface .....	2
Free FLASH Upgrades .....	2
CDMA Timing-How It Works .....	2
Where to Use It .....	3
<b>Chapter Two - Basic Installation .....</b>	<b>5</b>
Checking and Identifying the Hardware .....	5
Meridian Physical Description .....	6
Performing an Initial Site Survey .....	8
Installing the Meridian .....	9
Mount the Meridian .....	9
Connecting the DC Power Option .....	9
Installing the Antenna .....	10
Connecting and Configuring Ethernet .....	10
Configuring Ethernet with the Front-Panel Keypad .....	10

Configuring Ethernet with the Serial Port .....	10
Connect the RS-232 Serial I/O Port .....	11
Test the Serial Port .....	11
Using netconfig to Set Up Your IP .....	14
Verify Network Configuration .....	16
Check Network Operation .....	17
Using Telnet .....	18
Using SSH .....	18
Using HTTP .....	19
Connecting Instruments to the Meridian .....	19
<b>Chapter Three - Front-Panel Keypad and Display .....</b>	<b>21</b>
Display Description .....	21
Keypad Description .....	21
Display and Keypad Operation .....	22
Traversing the Display Structure .....	22
Editing .....	22
Keypad EDIT Lockout .....	23
Using Help .....	23
Shortcut Menu .....	23
Detailed Display Descriptions .....	23
Main Menu .....	24
Receiver Menu .....	24
Receiver Status .....	24
Channelset .....	25
Oscillator Status .....	25
Clock Calibration .....	26
TFOM Fault Level .....	26
Signal Loss Fault Mask .....	26
Clock Menu .....	26
Time Mode .....	26
Local Offset .....	26
Hours Display .....	26
Leap Seconds .....	27



Daylight Savings Time .....	27
CPU I/O Menu .....	27
1PPS Output Setup .....	27
Time Code Output Setup .....	27
Programmable TTL Output Setup .....	27
Synthesizer (DDS) Setup .....	27
Serial Time Output Setup .....	27
Display Setup .....	28
Faults .....	28
Network4 Setup .....	29
Network6 Setup (Optional) .....	29
NTP Menu .....	29
NTP Status .....	29
NTP Setup .....	30
PTP Menu (Optional) .....	30
Firmware .....	30
About .....	31

<b>Chapter Four - Control and Status Commands .....</b>	<b>33</b>
General Linux Shell Operation .....	33
Available User Commands .....	34
Detailed Command Descriptions .....	36
accessconfig .....	36
cdmacdelay .....	36
cdmachannelset .....	36
cdmaleapconfig .....	36
cdmaleapmode .....	37
cdmastat .....	37
cdmaversion .....	40
cptpstat (Optional) .....	40
cpuopts .....	40
cpuoptsconfig .....	40
cpusertime .....	40
cpusertimeconfig .....	41

---

csyshwaddr	41
csyosctype	41
csypasswd	41
csysrootfs	42
csysstat	42
cystimemode	43
cystimemodeconfig	43
csysversion	43
eraserootfs_1	43
help	44
inetdconfig	44
kplckstat	44
lockoutkp	44
netconfig	45
ntpconfig	45
oscctrlstat	45
pluginopts	46
pluginoptsconfig	46
ptpconfig and ptp2config (Optional)	46
ptpversionconfig (Optional)	46
setcdmacaldelay	47
setcdmachannelset	47
setsigfltmask	47
settfomfltmask	47
sigfltmask	47
tfomfltlvl	48
unlockkp	48
updaterootflag	48
upgradecdma	48
upgradekernel	49
<b>RS-232 Serial I/O Port Signal Definitions</b>	<b>49</b>

---

<b>Chapter Five - Setting Up the NTP Server</b> .....	51
Configuring the Network Time Protocol .....	51
Configuring NTP Using the Front-Panel Keypad .....	51
Configuring NTP Using the Network Interface or Serial Port .....	51
Configuring the Meridian as a Stratum 2 Server .....	54
Using Edit .....	54
 <b>Chapter Six - Optional Rear-Panel Outputs</b> .....	 55
CPU Module Options .....	55
Programmable TTL Output .....	55
Direct Digital Synthesizer (DDS) .....	56
Fixed Pulse Rate Output (10 MPPS, etc.) .....	56
1 PPS (RS-422) Output .....	56
Serial Time Output .....	56
Sysplex Format .....	56
Truetime Format .....	57
EndRun Format .....	57
EndRunX (Extended) Format .....	58
NENA Format .....	58
NMEA Format .....	59
Alarm Output .....	60
Plug-In Module Options .....	60
Programmable Digital Buffer Module .....	60
Digital Time Code Formats .....	61
Direct Digital Synthesizer (DDS) .....	61
Digital Buffer Module .....	61
Analog Time Code Buffer Module .....	62
Sine Wave Module .....	62
Low Phase Noise Module .....	63
Telecom Clock Module .....	64
User Settings .....	64
Alarms .....	66
Connectors and Cables .....	67

---

<b>Chapter Seven - HTTP Interface</b> .....	69
HTTP Interface Description .....	70
Navigation .....	70
Page Descriptions .....	71
Home Page .....	71
Receiver Page .....	72
Receiver (Oscillator) Page .....	73
Clock Page .....	73
I/O Page .....	74
I/O Page (Plug-In Options) .....	75
Faults Page .....	75
Network Page .....	76
Network (IPv6) Page .....	76
Network (DNS) Page .....	76
NTP Page .....	76
PTP Page .....	77
Firmware Page .....	77
Disabling The HTTP Protocol .....	77
<b>Appendix A - Time Figure-of-Merit (TFOM)</b> .....	79
<b>Appendix B - Upgrading the Firmware</b> .....	81
Upgrade Via The HTTP Interface .....	81
Upgrade Via The Network/Serial Port .....	83
Performing the Linux Subsystem Upgrade .....	83
Recovering from a Failed Upgrade .....	84
Performing the Linux Kernel Upgrade .....	85
Performing the CDMA Subsystem Upgrade .....	86
Problems with the CDMA Subsystem Upgrade .....	87
Recover Command .....	87
<b>Appendix C - Simple Network Management Protocol (SNMP)</b> .....	89
SNMPv3 Security .....	89
Enterprise Management Information Base (MIB) .....	89

---

Invocation of the SNMP daemon .....	90
Quick Start Configuration -- SNMPv1/v2c .....	90
Change Default Community Strings (Passwords) .....	91
Configuring SNMPv1 Trap Generation .....	91
Configuring SNMPv2c Notifications and Informs .....	91
Configuration of SNMPv3 .....	92
Disabling The SNMP Protocol .....	93
<b>Appendix D - Security .....</b>	<b>95</b>
Linux Operating System .....	95
Using Edit .....	96
Limiting Access .....	96
Disabling Protocols .....	97
Disable Telnet, TIME and DAYTIME .....	97
Disable SNMP and HTTP .....	97
Disable SSH .....	98
OpenSSH .....	98
Network Time Protocol .....	99
HTTP .....	100
<b>Appendix E - Setting Up NTP Clients on Unix-like Platforms .....</b>	<b>101</b>
Basic NTP Client Setup .....	102
Configure NTP .....	102
MD5 Authenticated NTP Client Setup .....	102
Create the ntp.keys File .....	103
Configure NTP .....	103
Broadcast/Multicast NTP Client Setup .....	104
Configure NTP Client for Broadcast .....	104
Configure NTP Client for Multicast .....	105
Test Broadcast/Multicast .....	105
<b>Appendix F - Setting Up NTP Clients on Windows NT 4.0/2000/XP .....</b>	<b>107</b>
Basic NTP Client Setup .....	108
Configure NTP .....	108

MD5 Authenticated NTP Client Setup .....	109
Create the ntp.keys File .....	109
Configure NTP .....	109
Broadcast/Multicast NTP Client Setup .....	110
Configure NTP Client for Broadcast .....	111
Configure NTP Client for Multicast .....	111
Test Broadcast/Multicast .....	112
<b>Appendix G - Time Code Formats .....</b>	<b>113</b>
IRIG-B122/002 .....	113
IRIG-B123/003 .....	113
IRIG-B120/000 (IEEE-Standard 1344-1995) .....	113
NASA-36 .....	113
2137 .....	113
IEEE-1344 Bit Definition .....	114
<b>Appendix H - Leap Seconds .....</b>	<b>115</b>
Background Information .....	116
<b>Appendix I - IPv6 Information .....</b>	<b>117</b>
Enabling New IPv6 Capabilities .....	117
OpenSSH .....	117
Net-SNMP .....	117
IPv6-Capable syslog-ng .....	118
IPv4-Only Protocols .....	118
<b>Appendix J - Third-Party Software .....</b>	<b>119</b>
GNU General Public License .....	119
NTP Software License .....	124
Apache Software License .....	124
PTP Software License .....	126

---

<b>Appendix K - Precision Time Protocol (PTP) IEEE-1588</b> .....	127
About PTP .....	127
Version PTPv2 or PTPv1 .....	128
Changing PTP Version Using the Keypad/Display .....	128
Changing PTP Version Using the Network or Serial Port .....	128
PTPv2 Configuration and Status .....	129
PTPv2 Configuration and Status Using the Keypad/Display .....	129
PTPv2 Configuration Using the Network or Serial Port .....	129
PTPv2 Status Using the Network or Serial Port .....	131
PTPv2 Operation .....	132
PTPv1 Configuration and Status .....	134
PTPv1 Configuration and Status Using the Keypad/Display .....	134
PTPv1 Configuration Using the Network or Serial Port .....	134
PTPv1 Status Using the Network or Serial Port .....	135
PTPv1 Operation .....	136
About the PTP Second and UTC Time .....	137
PTP Second .....	137
<b>Appendix L - Specifications</b> .....	139
<b>Special Modifications - Changes for Customer Requirements</b> .....	149





# Chapter One

## Introduction

*The Meridian CDMA Frequency Reference is a high-performance, full-featured system that provides highly-precise time and frequency outputs. The modular design allows for easy, field-installed upgrades that can satisfy virtually any time and frequency requirement. Advanced packaging techniques, coupled with compact card design, allow for the installation of up to five option boards in a single 1U chassis.*

*Incorporating a dual-frequency receiver with digital cellular (800 MHz) and PCS (1.9 GHz) capability, the Meridian uses the CDMA wireless infrastructure to precisely synchronize itself to Universal Coordinated Time (UTC) to the 10-microseconds level of accuracy. The frequency of the internal oscillator is disciplined to match the frequency of the UTC timescale to the low parts in  $10^{12}$  level of accuracy over 24-hour observation intervals.*

*For more detailed information that is not included in this manual, and links to other sites, please visit our website: <http://www.endruntechnologies.com>. There you can also download firmware upgrades, the latest manuals and other documentation.*

## Main Features

### Overview

The Meridian is composed of a Code Division Multiple Access (CDMA) time and frequency engine integrated with an IBM-PC compatible fanless, convection-cooled 133 MHz CPU with integral ethernet interface and a power supply. Non-volatile storage of the embedded Linux operating system and the Meridian application software is via FLASH memory.

### Highly-Reliable, Modular Design

The Meridian provides high performance and reliability combined with low power consumption and cost. Its internal sub-assemblies are fabricated using state-of-the-art components and processes and are integrated in a solid, high-quality chassis. A complete suite of time and frequency capabilities with an exceptionally high number and variety of outputs are provided in its standard 1U high, 19" rack-mountable chassis. The modular, plug-and-play design of the Meridian and a wide range of option cards make it easy to tailor the unit to support your applications.

### Standard Features

In addition to sourcing a precision 1PPS timing reference and an IRIG-B timecode output, your Meridian includes a network port with high-bandwidth Network Time Protocol (NTP). The Meridian incorporates a vibrant 16x280 dot-matrix vacuum-fluorescent display and a user-friendly keypad design for control and status monitoring. The Meridian can also be managed via the network port or a local console on the RS-232 serial port. See **Chapter 3 - Front-Panel Display and Keypad**, **Chapter 4 - Control and Status Commands**, and **Chapter 5 - NTP** for more information.

**Secure Network Interface**

An ethernet port is provided as a standard feature of the Meridian with a wide variety of protocols including NTP, SNMP with Enterprise MIB, SSH, TELNET, FTP, and SNTP. Refer to **Chapter 2 - Basic Installation** for information to help you set up your network interface. The inclusion of SNMP v3 and SSH provides a very secure network interface and allows you to safely perform monitoring and maintenance activities over the network. Security-conscious users can also disable any or all of the risky protocols such as Telnet, Time and Daytime. In addition, access via SSH, SNMP and Telnet can be restricted to specific hosts. Refer to **Appendix C - SNMP** and **Appendix D - Security** for further information.

**Free FLASH Upgrades**

Firmware and configurable hardware parameters are stored in non-volatile FLASH memory, so the Meridian can be easily upgraded in the field using FTP and TELNET or the local RS-232 serial I/O port. Secure upgrades are possible via SSH and SCP. We make all firmware upgrades to our products available to our customers free of charge.

**CDMA Timing-  
How It Works**

The CDMA time and frequency engine in the Meridian receives transmissions from base stations, also known as cell sites, that are operating in compliance with the TIA/EIA IS-95 standard for Code Division Multiple Access (CDMA) mobile telecommunications. This system requires a means of synchronizing the base stations throughout the network so that neighboring cells do not interfere with each other and so that calls can be efficiently transferred between the base stations, without interruption, as the mobile user traverses the cell coverage areas. This ‘soft hand-off’ feature means that the mobile telephone must be able to ‘hitlessly’ drop one base station and pick up the next one. To do this, the telephone must be able to calculate the relative difference in time between the codes that modulate the signals from each of the base stations, which again, requires that the base stations be synchronized.

The system designers chose the Global Positioning System (GPS), which is itself a CDMA-based system, as the means of maintaining synchronization, and they defined *system time* to be *GPS time*. Each base station throughout the system contains one or more high-performance GPS timing receivers with sophisticated algorithms that control either an extremely stable ovenized quartz crystal oscillator or a Rubidium vapor atomic frequency standard. Such elaborate means are needed to meet the very difficult operating specifications required by the TIA/EIA IS-95 standard. The base station time synchronization must remain within 10 microseconds of GPS time over periods as long as twenty-four hours during which GPS satellite signals might not be available (typically due to antenna/cable failure, damage or vandalism) and in an environment where large ambient temperature swings may occur. Equipment capable of meeting these requirements is at the current state-of-the-art.

The CDMA time and frequency engine in the Meridian receives the same initialization signals transmitted by the base stations that are used by the mobile telephones to establish their synchronization to system time. The mobile telephones cannot communicate in the system until they have established synchronization with the received spread spectrum encoded waveform. Unlike the mobile telephones, once this synchronization has occurred, the CDMA time and frequency engine in the Meridian has all of the information that it needs to perform its function of delivering accurate UTC time to a network of computers. The mobile telephone must decode much more information, establish two-way communications with the base station, and be a paid subscriber to perform its function of placing and receiving calls.

---

All of this means that during normal operation, the quality of the timing information being transmitted from each of the base stations is virtually a repeat of that directly obtainable from the GPS. The big difference is that the received signal strengths from the base stations are a minimum of 30 dB larger than those from the GPS satellites, which is why you can usually talk on your cell phone indoors. Due to the nature of the IS-95 spread spectrum CDMA modulation scheme, this timing information may be extracted by a well-designed receiver with a precision of a few nanoseconds. The CDMA time and frequency engine in the Meridian does just that, and for this reason, we call our technology 'indirect GPS'.

## **Where to Use It**

First, the Meridian must be deployed in a *cellular* or *PCS* IS-95 CDMA coverage area. *Cellular* is a commonly used term implying that the frequency band for the base station carrier transmissions is 824-895 MHz. This is in contrast to *PCS*, which implies operation in the 1850-1990 MHz frequency band. If available, the Meridian uses the cellular frequency band because it provides much better propagation characteristics in regards to building penetration and maximum receivable range from the transmitter. In regions lacking cellular coverage, the unit can be set to receive the PCS signals. In general, if your CDMA telephone works where you plan to install the Meridian, then your Meridian will work properly there.



# Chapter Two

## *Basic Installation*

*This chapter will guide you through the most basic checkout and physical installation of your Meridian CDMA Frequency Reference. Subsequent chapters and appendices will give you the information needed to configure your installation for the maximum performance in your operating environment. Though some familiarity with Linux or other Unix-like operating systems would be helpful, it is not essential. When operating your Meridian with its standard network interface, basic familiarity with TCP/IP protocols like **ping**, **telnet** and **ftp** is required.*

### **Checking and Identifying the Hardware**

Unpack and check all the items using the shipment packing list. Contact the factory if anything is missing or damaged. The Meridian shipment typically contains:

- Meridian (part # 3025-0101-000 or #3025- variant)
- Meridian User Manual (part #USM3025-0000-000) on CD (part #5102-0001-000)
- IEC 320 AC Power Cord (part #0501-0003-000)  
(This part will not be present if using the DC power option.)
- DB9F-to-DB9F Null Modem Serial I/O Cable (part #0501-0002-000)
- RJ-45 to RJ-45 CAT-5 patch cable, 2 meters (part #0501-0000-000)
- Antenna/cable assembly (part #0502-0007-001)

**Meridian Physical Description**

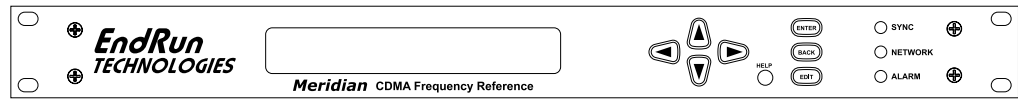

- Sync LED This green LED flashes to indicate synchronization status.
- Network LED This amber LED illuminates when the Meridian is connected to the network and flashes when receiving or transmitting packets..
- Alarm LED This red LED illuminates briefly at power-up, and thereafter whenever a serious fault condition exists.

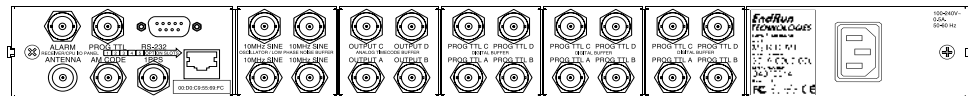

- Antenna Jack This TNC connector mates with the download cable from the external antenna.
- RS-232 Connector This DB-9M connector provides the RS-232 serial I/O console interface to the Meridian. This console allows the user to initialize and maintain the Meridian. See *Chapter 4 - RS-232 Serial I/O Port Signal Definitions* for detailed information.
- 10/100Base-T Jack This RJ-45 connector mates with the ethernet twisted pair cable from the network.
- 1PPS Jack This BNC connector provides the 1PPS Output (TTL). The pulse width is normally 1 millisecond wide when shipped from the factory but can be changed via the front-panel keypad or via console command **cpuoptsconfig**. Other selections are 20 microseconds, 100 milliseconds and 500 milliseconds. See signal definition in *Appendix L - Specifications* for the 1PPS Output.
- AM Code Jack This BNC connector provides the amplitude-modulated time code output. The time code output is normally IRIG-B122 when shipped from the factory, but can be changed via the front-panel keypad or via console command **cpuoptsconfig**. Other selections are available. See signal definition in *Appendix L - Specifications* for the AM Code Output.
- Alarm Jack (Option) This BNC connector (or terminal strip) provides the optional Alarm Output, and is usually not installed. If installed, see description in *Chapter 6 - Optional Rear-Panel Outputs* and signal definition in *Appendix L - Specifications*.

<p>Prog TTL Jack (Option)</p>	<p>This BNC connector provides the optional Programmable TTL Output and is usually not installed. If installed, see description in <i>Chapter 6 - Optional Rear-Panel Outputs</i> and signal definition in <i>Appendix L - Specifications</i>.</p>
<p>10 MPPS or 100 PPS, etc. (Option)</p>	<p>This BNC connector provides an optional customer-specified rate output and is usually not installed. If installed, it will be labeled for the appropriate rate such as “10 MPPS” or “100 PPS”, etc. This output is set at the factory and cannot be changed. See details in <i>Chapter 6 - Optional Rear-Panel Outputs</i> and signal definition in <i>Appendix L - Specifications</i> for the Fixed Pulse Rate Output.</p>
<p>1PPS (RS-422) (Option)</p>	<p>This optional DB-9M connector provides the 1PPS Output at RS-422 levels and is usually not installed.. The pulse width is normally 1 millisecond wide when shipped from the factory but can be changed via the front-panel keypad or via command <code>cpuoptsconfig</code>. See pinout details in <i>Appendix L - Specifications</i> for the 1PPS RS-422 Output.</p>
<p>Serial Time (Option)</p>	<p>This optional DB-9M connector provides the serial I/O interface with a once-per-second ASCII time string output and is usually not installed. For further information refer see description in <i>Chapter 6 - Optional Rear-Panel Outputs</i> and <i>Appendix L - Specifications</i>.</p>
<p>Plug-In Modules (Options)</p>	<p>Your Meridian has five option slots that can be configured with a variety of plug-in modules. See <i>Chapter 6 - Optional Rear-Panel Outputs</i> for detailed information on the various modules.</p>
<p>AC Power Input Jack</p>	<p>This IEC 320 standard three-prong connector provides AC power.</p>
<p>DC Power Input Block (Option)</p>	<p>This optional 3-position terminal block provides connection to the DC power source, and replaces the AC power input jack. See details in <i>Appendix L - Specifications</i>.</p>
<p>Dual Power Supplies (Option)</p>	<p>This option provides an additional power supply, which is permanently installed in two of the option slots. The two power supplies, which may be any combination of AC-input or DC-input power options, are not field-swappable. Power Supply A (primary) and Power Supply B (secondary) are connected in a dual-redundant configuration with hitless automatic A-to-B and B-to-A switchover. The chassis is sourced from Power Supply A as long as it is operational and is supplied with external power.</p>

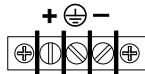

## **Performing an Initial Site Survey**

Using the status LED indicators, it's easy to find out if your Meridian will work in your desired location:

1. Screw the TNC plug on the end of the antenna cable onto the TNC antenna input jack on the chassis rear panel of the Meridian.
2. Plug one end of the supplied AC power cord into an 85-270 VAC outlet.
3. Plug the other end into the AC input connector on the chassis rear panel of the Meridian.

Place the antenna on a flat, preferably metallic surface while the unit is searching for the signal. Make sure that it is not blocked by large metallic objects closer than one meter. Although the antenna should normally be installed in a vertical orientation, usually multipath conditions due to signal reflections indoors cause at least some of the signal to be horizontally polarized, so do not be surprised if you find that the unit will work with the antenna oriented either way. Multipath conditions can also cause another effect: signal cancellation. Since the wavelength of the signal is only about 12 to 30 centimeters, movement of the antenna just a few centimeters can sometimes cause significant signal strength changes.

Initially upon power up:

1. The unit will light the red Alarm Status LED for about ten seconds.
2. Then it will continuously light the green Sync Status LED.
3. When the unit has detected a CDMA signal, the green Sync Status LED will begin to flash very slowly (about a .4 Hz rate). Note: If your unit has an oscillator upgrade (OCXO or Rb) then it will need to warm up for 5-10 minutes before attempting to acquire a signal.
4. As the unit locks onto the CDMA signal and begins to decode the timing data, the green Sync Status LED will flash very rapidly (about a 6 Hz rate) until the data is fully decoded.
5. Then the green Sync Status LED will pulse at precisely a 1 Hz rate, synchronized to UTC seconds, with a short on duration relative to the off duration.

At this point, the CDMA time and frequency engine has fully synchronized, and you may proceed to permanently mount the chassis and antenna in the desired location.

If this sequence has not occurred within twenty minutes (30 minutes with OCXO or Rb), you should move the antenna and/or change its orientation and retry. If you are unable to find an antenna location where the unit will acquire the CDMA signals, you may not have *cellular* coverage in your area or the signal might be too weak in your facility. First, using the `setcdmachannelset` command, try changing the channelset on your unit to operate with the PCS frequencies. If you are still unable to receive signals, you should continue to try for at least a day, since base stations are taken down for service from time to time.

If you have a CDMA phone, see if it will work in *digital* mode. If it will, then your Meridian may be damaged and should be returned to the factory for repair or exchange.



**NOTE**

If your unit has a medium-stability OCXO (MS-OCXO) or rubidium (Rb) oscillator then it will require a 5-10 minute warm-up period before it begins searching for a CDMA signal.

**Installing the Meridian****FCC NOTICE**

This equipment has been tested and found to comply with the limits for a Class A digital device, pursuant to part 15 of the FCC Rules. These limits are designed to provide reasonable protection against harmful interference when the equipment is operated in a commercial environment. This equipment generates, uses, and can radiate radio frequency energy and, if not installed and used in accordance with the instruction manual, may cause harmful interference to radio communications. Operation of this equipment in a residential area is likely to cause harmful interference in which case the user will be required to correct the interference at his own expense.

**Mount the Meridian**

Using standard 19" rack mounting hardware, mount the unit in the previously surveyed location.

**CAUTION**

Ground the unit properly with the supplied power cord.

Position the power cord so that you can easily disconnect it from the Meridian.

Do not install the Meridian where the operating ambient temperature might exceed 122°F (50°C).

**Connecting the DC Power Option**

Connect the safety ground terminal to earth ground. Connect the "+" terminal to the positive output of the DC power source. Connect the "-" terminal to the negative output of the DC power source. Note that the Meridian has a "floating" internal power supply, therefore either the positive or negative output of the DC power source can be referenced to earth ground. This unit will not operate if the +/- connections are reversed; however it will not be damaged by a reverse connection.

**SHOCK/ENERGY HAZARD**

Install in Restricted Access Location.

Use 10-14 AWG copper wire only.

Terminal block screw torque: 9 in-lbs (1 nM).

Branch circuit must have circuit breaker, 15A or less.

Install terminal block cover after wiring.

**Installing the Antenna**

Make sure that the antenna is not blocked by metallic objects that are closer than about one meter. A good location is the top surface of the equipment rack into which the unit has been installed. Ideally it should be mounted vertically, as the transmitted signals are vertically polarized. When indoors, however, multipath conditions may exist. This means that reflected signals may be present with either vertical or horizontal polarization, so your antenna might work in either orientation. After mounting the unit and antenna, verify that it still acquires and tracks a CDMA signal.

**Connecting and Configuring Ethernet**

Connect one end of the CAT-5 patch cable supplied with your Meridian to the rear-panel-mounted RJ-45 connector labeled 10/100BASE-T. Connect the other end of the patch cable to your network through a 'straight' port on your hub. Do not connect it to a 'crossover' port on your hub.

By factory default, the Meridian will attempt to configure the ethernet interface automatically via the Dynamic Host Configuration Protocol (DHCP). The Meridian will attempt to set the netmask, its IP address, the IP address of the default gateway, the domain name and the IP addresses of any nameservers, if the DHCP server is configured to provide them. You may optionally configure the Meridian to also set its hostname via DHCP, if your DHCP server is configured to provide it. You can do this by running a simple shell script called **netconfig** after your unit is up on the network.

If your network *does* use DHCP for host configuration, and you are in a hurry to get your Meridian up and running, you may proceed to **Verifying Network Configuration** to make sure that the network parameters were set up correctly. Otherwise, it is recommended that you read the following sections on use of the RS-232 serial I/O port now, since they will help you in debugging any problems that you may encounter with the automatic configuration via DHCP.

If your network *does not* use DHCP, you will need to configure your ethernet interface using either the front-panel keypad or the RS-232 serial I/O port. The following sections contain brief descriptions on how to do that.

**Configuring Ethernet with the Front-Panel Keypad**

Configuring your ethernet interface with the front-panel keypad is quite simple. After the unit has powered on, press the ENTER key once or twice until you see a display called Main Menu. Now press the RIGHT arrow key until the "Network" selection is highlighted. Press ENTER again. You will see the IP address, gateway and netmask settings displayed here. Press the EDIT key to modify these settings. The sequence of edit displays will guide you through the setup process. Press the HELP key at any time to view context-sensitive help information. When you are finished the unit will reset. Skip to the section called **Check Network Operation** later in this chapter to continue with the basic installation procedures.

**Configuring Ethernet with the Serial Port**

To configure your ethernet interface with the serial port, after logging in as the *root* user, you must run a simple shell script called **netconfig** from the **bash** shell prompt. This shell script will prompt you for the needed information and perform some syntax checking on your inputs. Then it will create or modify the appropriate files needed to configure the ethernet interface. The following sections will guide you in setting up communications with the Meridian using its RS-232 serial I/O port.

**Connect the RS-232 Serial I/O Port**

You will need to use the RS-232 serial I/O port if your network does not support the Dynamic Host Configuration Protocol (DHCP). In that case, you must be able to configure the Meridian network parameters manually using the Linux console shell interface which is provided by this serial I/O port. Under certain conditions, you may also need to use the RS-232 serial I/O port if you encounter a problem while upgrading the firmware in your Meridian.

To test serial communications with the Meridian you will need either a VT100 compatible terminal or a terminal emulation program running on your computer. We will refer to either of these as “terminal” for the remainder of this instruction.

1. Disconnect power from the Meridian.
2. Connect one end of the DB9F-to-DB9F null modem adapter cable to the serial I/O jack on the Meridian.
3. Connect the other end of the DB9F-to-DB9F null-modem adapter cable to the terminal. If the serial I/O port on your terminal does not have a DB9M connector, you may need to use an adapter. Refer to *Chapter 4 - RS-232 Serial I/O Port Signal Definitions* for details on the signal wiring. *If you are using a computer for your terminal, remember which port you are using because you will need to know that in order to set up your terminal software.*

**Test the Serial Port**

You must configure your terminal to use the serial I/O port you used in *Connect the RS-232 Serial I/O Port*. You must also configure your terminal to use the correct baud rate, number of data bits, parity type and number of stop bits. *Be sure to turn off any hardware or software handshaking.* The settings for the Meridian are:

- 19200 is the Baud Rate
- 8 is the number of Data Bits
- None is the Parity
- 1 is the number of Stop Bits

After configuring these parameters in your terminal, apply power to the Meridian. After about 20 seconds, your terminal should display a sequence of boot messages similar to these:

```
*****
* 6010-0040-000 Linux Bootloader v1.00 08/17/2004 *
*****
Default root file system: FACTORY
To override and boot the UPGRADE partition type 'UPGRADE' within 5 seconds...
.....
```

These lines are the Linux bootloader boot prompt. This prompt will timeout after 5 seconds and the Linux kernel and the factory default Meridian root file system will be loaded. When the Linux kernel is loaded from FLASH memory into RAM a long list of kernel-generated, informational messages is displayed as the kernel begins execution and the various device drivers are initialized:

```
Booting Linux with FACTORY root file system...
```

---

## CHAPTER TWO

```
6010-0041-000 Linux Kernel v2.4.26-1 #0 Wed Aug 18 17:28:45 UTC 2004
BIOS-provided physical RAM map:
BIOS-88: 0000000000000000 - 00000000009f000 (usable)
BIOS-88: 000000000100000 - 000000000200000 (usable)
32MB LOWMEM available.
On node 0 totalpages: 8192
zone(0): 4096 pages.
zone(1): 4096 pages.
zone(2): 0 pages.
DMI not present.
Kernel command line: config=11000001 initjffs=0 console=ttyS0,19200 root=/dev/
mtdblock4 load_ramdisk=1 rw
Initializing CPU#0
Calibrating delay loop... 66.96 BogoMIPS
Memory: 30784k/32768k available (812k kernel code, 1596k reserved, 162k data, 68k
init, 0k highmem)
Checking if this processor honours the WP bit even in supervisor mode... Ok.
Dentry cache hash table entries: 4096 (order: 3, 32768 bytes)
Inode cache hash table entries: 2048 (order: 2, 16384 bytes)
Mount cache hash table entries: 512 (order: 0, 4096 bytes)
Buffer cache hash table entries: 1024 (order: 0, 4096 bytes)
Page-cache hash table entries: 8192 (order: 3, 32768 bytes)
CPU: AMD 486 DX/4-WB stepping 04
Checking 'hlt' instruction... OK.
POSIX conformance testing by UNIFIX
PCI: Using configuration type 1
PCI: Probing PCI hardware
PCI: Probing PCI hardware (bus 00)
Linux NET4.0 for Linux 2.4
Based upon Swansea University Computer Society NET3.039
Initializing RT netlink socket
Starting kswapd
JFFS2 version 2.1. (C) 2001 Red Hat, Inc., designed by Axis Communications AB.
Serial driver version 5.05c (2001-07-08) with MANY_PORTS SHARE_IRQ SERIAL_PCI enabled
ttyS00 at 0x03f8 (irq = 4) is a 16550A
ttyS01 at 0x02f8 (irq = 3) is a 16550A
ttyS02 at 0x03e8 (irq = 0) is a ST16654
ttyS03 at 0x02e8 (irq = 3) is a ST16654
sc520_wdt: CBAR: 0x800df000
sc520_wdt: MMCR Aliasing enabled.
sc520_wdt: WDT driver for SC520 initialised.
RAMDISK driver initialized: 16 RAM disks of 16384K size 1024 blocksize
pcnet32.c:v1.28 02.20.2004 tsbogend@alpha.franken.de
PCI: Enabling device 00:0d.0 (0000 -> 0003)
pcnet32: PCnet/FAST III 79C973 at 0x1000, 00 0e fe 00 00 33
tx_start_pt(0x0c00):~220 bytes, BCR18(9a61):BurstWrEn BurstRdEn NoUFlow
SRAMSIZE=0x1700, SRAM_BND=0x0800, assigned IRQ 12.
eth0: registered as PCnet/FAST III 79C973
pcnet32: 1 cards_found.
Tempus SC520 flash device: 1000000 at 2000000
Amd/Fujitsu Extended Query Table v1.3 at 0x0040
number of CFI chips: 1
Creating 7 MTD partitions on "Tempus SC520 Flash Bank":
0x00000000-0x000e0000 : "Tempus kernel"
mtd: Giving out device 0 to Tempus kernel
0x000e0000-0x00100000 : "Tempus Lo BootLdr"
mtd: Giving out device 1 to Tempus Lo BootLdr
0x00100000-0x00200000 : "Tempus /boot"
mtd: Giving out device 2 to Tempus /boot
0x00200000-0x00300000 : "Tempus /logs"
mtd: Giving out device 3 to Tempus /logs
0x00300000-0x00900000 : "Tempus FACTORY rootfs"
mtd: Giving out device 4 to Tempus FACTORY rootfs
```

---

## BASIC INSTALLATION

```
0x00900000-0x00fe0000 : "Tempus UPGRADE rootfs"
mtd: Giving out device 5 to Tempus UPGRADE rootfs
0x00fe0000-0x01000000 : "Tempus Hi BootLdr"
mtd: Giving out device 6 to Tempus Hi BootLdr
NET4: Linux TCP/IP 1.0 for NET4.0
IP Protocols: ICMP, UDP, TCP, IGMP
IP: routing cache hash table of 512 buckets, 4Kbytes
TCP: Hash tables configured (established 2048 bind 2048)
NET4: Unix domain sockets 1.0/SMP for Linux NET4.0.
mtdblock_open
ok
RAMDISK: Compressed image found at block 0
mtdblock_release
ok
VFS: Mounted root (ext2 filesystem).
Freeing unused kernel memory: 68k freed
INIT: version 2.76 booting
/etc/rc.d/rc.S: /bin: is a directory
mtdblock_open
ok
mtdblock_open
ok
Loading CDMA
Loading Keypad/VFD
Fri Aug 20 00:53:54 2004 -0.707128 seconds
2004
Setting system time using hwclock
INIT: Entering runlevel: 3
Entering multiuser...
Attempting to configure eth0 by contacting a DHCP server...
```

At this point, if you do not have a DHCP server configured on your network the unit will time-out and print these messages:

```
Meridian CDMA DHCP Client was unable to find the DHCP Server!
Fix the problem and re-boot or set up static IP address
by running netconfig.
dnsdomainname: Host name lookup failure
(none)
```

Then these messages are printed, in either case:

```
Disabling IPv4 packet forwarding...
Starting daemons: syslogd klogd inetd
Starting the Network Time Protocol daemon...
Starting the SNMP daemon...
Starting the system logfile manager...
Starting the system watchdog...woof!
Starting Keypad/Display Process
```

During this process, the factory default MeridianCDMA\_0 root file system is loaded from FLASH disk to an 16MB ramdisk and the remainder of the boot process completes. At this point, the Meridian login prompt is displayed:

```
*****
*           Welcome to Meridian CDMA console on:  csys.your.domain
*           Tue Feb 20  2001 21:47:03 UTC
*****
csys login:
```

Here you may log in as “csysuser” with password “Praecis” or you may log in as the “root” user with password “endrun\_1”. When logged in as “csysuser”, you may check status information and view log files but you will not be able to modify any system settings or view secure files. In order to perform system setup procedures, which includes configuring the IP network settings, you must log in as the “root” user. After correctly entering the password at this prompt,

**password:**

the sign on message is shown. It identifies the host system as Meridian CDMA and shows the software part number, version and build date:

```
Meridian CDMA 6010-0042-000 v 1.00 Wed May 9 14:17:44 UTC 2002
Meridian CDMA (root@csys:~)->
```

This last line is the standard Meridian shell prompt. The Meridian uses the **bash** shell, which is the Linux standard, full-featured shell. After configuring the unit, you should change the passwords using the **csyspasswd** command issued from the shell prompt.

If you do not see characters displayed by your terminal program within 30 seconds after the unit is powered up, you must troubleshoot your setup. An incorrectly wired cable or incorrect port setting in your terminal emulation program are the most common problems. Refer to *Chapter 4 - RS-232 Serial I/O Port Signal Definitions* for the signal connections for the Meridian.

#### **NOTE**

You must use a null-modem cable or adapter if you are connecting the Meridian to another computer or other equipment configured as Data Terminal Equipment (DTE). The supplied cable is a null-modem cable.

Once you have successfully established communications with the Meridian, you may proceed to configuring the network parameters. Then you can communicate with the Meridian over the network using **telnet** or **ssh** and synchronize your network computers to UTC using NTP.

#### **Using netconfig to Set Up Your IP**

The script file **netconfig** will configure the TCP/IP network parameters for your Meridian. If you want to have the HTTP Interface enabled in your Meridian then be sure to configure the name server IP address during the **netconfig** process. The HTTP Interface will not start if this is configured incorrectly. Only one name server is required, two gives some redundancy.

The following is a sample transcript which illustrates the use of **netconfig**. The entries made by the user are underlined and are provided purely for illustrative purposes. You must provide equivalent entries that are specific to your network. Those shown here are appropriate for a typical network that does not use DHCP. Start the configuration process by typing **netconfig** at the shell prompt:

---

## BASIC INSTALLATION

```
Meridian CDMA(root@csys)-> netconfig
*****
***** Meridian CDMA Network Configuration *****
*****
*
* This script will configure the TCP/IP network parameters for your
* Meridian CDMA. You will be able to reconfigure your system at any time
* by typing:
*
* netconfig
*
* The settings you make now will not take effect until you restart your
* Meridian CDMA, so if you make a mistake, just re-run this script before
* re-booting.
*
* You will be prompted to enter your network parameters now.
*
*****
*****

---DHCP Settings
Use a DHCP server to configure the ethernet interface? ([y]es, [n]o) n

---HOST name setting

Set the hostname of your Meridian CDMA. Only the base
hostname is needed, not the domain.
Enter hostname: csys

---DOMAIN name setting

Set the domain name. Do not supply a leading `.'
Enter domain name for csys: your.domain

---STATIC IP ADDRESS setting

Set the IP address for the Meridian CDMA. Example: 111.112.113.114
Enter IP address for csys (aaa.bbb.ccc.ddd): 192.168.1.245

---DEFAULT GATEWAY ADDRESS setting

Set the default gateway address, such as 111.112.113.1
If you don't have a gateway, just hit ENTER to continue.
Enter default gateway address (aaa.bbb.ccc.ddd): 192.168.1.241

---NETMASK setting

Set the netmask. This will look something like this: 255.255.255.0
Enter netmask (aaa.bbb.ccc.ddd): 255.255.255.248

Calculating the BROADCAST and NETWORK addresses...
Broadcast = 192.168.1.247      Network = 192.168.1.240

Your Meridian CDMA's current IP address, full hostname, and base hostname:
192.168.1.245      csys.your.domain      csys

---DOMAIN NAMESERVER(S) address setting

Will your Meridian CDMA be accessing a nameserver ([y]es, [n]o)? y

Set the IP address of the primary name server to use for domain your.domain.
Enter primary name server IP address (aaa.bbb.ccc.ddd): 192.168.1.1
```

Will your Meridian CDMA be accessing a secondary nameserver ([y]es, [n]o)? y

Set the IP address of the secondary name server to use for domain your.domain.  
Enter secondary name server IP address (aaa.bbb.ccc.ddd): 192.168.1.2

Setting up TCP/IP...  
Creating /etc/HOSTNAME...  
Creating /etc/rc.d/rc.inet1...  
Creating /etc/networks...  
Creating /etc/hosts...  
Creating /etc/resolv.conf...

```
*****
*****
*
*           The Meridian CDMA network configuration has been updated.           *
*
*           Please re-boot now for the changes to take effect.                   *
*
*****
*****
```

### Verify Network Configuration

If you have made changes to your network configuration using **netconfig**, you should shutdown the Meridian and reboot it. There are two ways to do this:

1. Cycle power to the Meridian.
2. Issue the shutdown with reboot command at the shell prompt:

```
Meridian CDMA(root@csys:~)-> shutdown -r now
```

If you are using the RS-232 serial I/O port to communicate with the Meridian, you will be able to see the kernel generated boot messages when the unit reboots. You should note the line

```
Configuring eth0 as 192.168.1.245...
```

if you have set up a static IP address, or this line

```
Attempting to configure eth0 by contacting a DHCP server...
```

if you are using DHCP. It appears near the end of the kernel generated boot messages.

If you are using DHCP and are not using the RS-232 serial I/O port, you will have to check the DHCP configuration information maintained by your DHCP server to determine the expected IP address and log in to the Meridian using **telnet** or **ssh** to verify successful DHCP configuration. Refer to the subsequent topics in this section *Using Telnet* and *Using SSH*, for details on logging in to the Meridian that way. Once you have logged in, you may perform the following checks.

If you are not using DHCP, the IP address shown should match the static IP address which you entered during the **netconfig** procedure. If so, log in as “root” at the login prompt and check the other configuration parameters using **ifconfig**:



```
Meridian CDMA(root@csys:~)-> ifconfig
```

```
eth0      Link encap:Ethernet  HWaddr 00:0E:FE:00:00:34
          inet addr: 192.168.1.245 Bcast:192.168.1.247 Mask:255.255.255.248
          UP BROADCAST RUNNING MULTICAST  MTU:1500  Metric:1
          RX packets:3779 errors:0 dropped:0 overruns:0 frame:0
          TX packets:727 errors:0 dropped:0 overruns:0 carrier:0
          collisions:0 txqueuelen:100
          Interrupt:5 Base address:0x300

lo        Link encap:Local Loopback
          inet addr:127.0.0.1  Mask:255.0.0.0
          UP LOOPBACK RUNNING  MTU:3924  Metric:1
          RX packets:170 errors:0 dropped:0 overruns:0 frame:0
          TX packets:170 errors:0 dropped:0 overruns:0 carrier:0
          collisions:0 txqueuelen:0
```

Pay particular attention to the settings shown for **eth0** and in particular the **Mask**: setting, which should match that which is appropriate for your network. Now check the remaining configuration parameters using **route**:

```
Meridian CDMA(root@csys:~)-> route
```

```
Kernel IP routing table
Destination    Gateway         Genmask         Flags Metric Ref Use Iface
localnet      *               255.255.255.248 U    0      0  0 eth0
loopback      *               255.0.0.0      U    0      0  0 lo
default       192.168.1.241  0.0.0.0        UG   1      0  0 eth0
```

Here you are interested in the default gateway address. It should match the appropriate one for your network. If so, then the ethernet interface of your Meridian has been successfully configured to operate on your network and you are ready to check operation of the Meridian over the network. If not, you should recheck your configuration and/or repeat the **netconfig** procedure.

If you have configured a nameserver(s) for your network, you may check that by issuing this shell command:

```
Meridian CDMA(root@csys:~)-> cat /etc/resolv.conf
```

```
search your.domain
nameserver 192.168.1.1
nameserver 192.168.1.2
```

Which displays the contents of the */etc/resolv.conf* file containing your domain name and the nameserver IP address(es) to use for that domain.

### Check Network Operation

With your Meridian network parameters properly configured, you are ready to test the setup using **ping** from a server or workstation that is able to access the network connected to the Meridian. Alternatively, you could **ping** one of your servers or workstations from the Meridian shell prompt to test the setup.

Once you have successfully established network communications with the Meridian, you may perform all maintenance and monitoring activities via **telnet** and **ftp**. The Meridian provides both client and server operation using **telnet**. For security reasons as well as to reduce the memory

footprint in the Meridian, only client operation is supported using **ftp**. You may also monitor the Meridian via the HTTP interface (see *Chapter 7 - HTTP Interface*).

Security conscious users will want to use **ssh**, the secure shell replacement for **telnet**, as the login means. The companion utility, **scp** provides a secure replacement for **ftp** as a means of transferring files to and from the Meridian. Both of these protocols are supported in the Meridian via the OpenSSH implementations for Linux. Refer to *Appendix D - Security* for more information about the secure shell protocol.

### Using Telnet

When establishing a **telnet** connection with your Meridian, logging in directly as **root** is not permitted. This is a security measure that makes it slightly more difficult to gain access by simply trying passwords, since it is also necessary to know the name of a user. When you initiate a **telnet** session with the Meridian, this banner will be displayed:

```
*****  
*           Welcome to Meridian CDMA telnet console on:  csys.your.domain  
*****
```

**csys login:**

Here you may log in as “csysuser” with password “Praecis”. When logged in as “csysuser”, you may check status information and view log files but you will not be able to modify any system settings or view secure files. After correctly entering the password at this prompt,

**Password:**

the sign on message is shown. It identifies the host system as Meridian CDMA and shows the software part number, version and build date:

```
Meridian CDMA 6010-0004-000 v 1.00 Wed May 16 14:17:44 UTC 2002  
Meridian CDMA(root@csys:~)->
```

This last line is the standard Meridian shell prompt. The Meridian uses the **bash** shell, which is the Linux standard, full-featured shell. After configuring the unit, you should change the passwords using the **csyspasswd** command issued from the shell prompt.

To gain **root** access, you must now issue the “super user” command at the shell prompt:

```
Meridian CDMA(root@csys:~)-> su root
```

You will then be prompted for the password, which is “endrun\_1”, and be granted **root** access to the system. To leave “super user” mode, issue the shell command **exit**. Issuing **exit** again will close the **telnet** session.

### Using SSH

When establishing a **ssh** connection with your Meridian, logging in directly as **root** is permitted. When you log in as **root** via a **ssh** session with the Meridian, this banner will be displayed:

```
*****  
*           Welcome to Meridian CDMA SSH console on:  csys.your.domain  
*****
```

**root@csys.your.domain's password:**

Here you may log in as “root” with password “endrun\_1”. After correctly entering the password the sign on message is shown. It identifies the host system as Meridian and shows the software part number, version and build date:

```
Meridian CDMA 6010-0042-000 v 1.00 Fri Aug 20 14:17:44 UTC 2004
Meridian CDMA(root@csys:~)->
```

This last line is the standard Meridian shell prompt. The Meridian uses the **bash** shell, which is the Linux standard, full-featured shell. After configuring the unit, you should change the passwords using the **csyspasswd** command issued from the shell prompt.

Issuing **exit** will close the **ssh** session.

### Using HTTP

You may monitor the status of the Meridian via the HTTP interface. For security reasons, you may not change any settings via the HTTP interface. See *Chapter 5 - HTTP Interface* for more information.

### IMPORTANT

SSH, Telnet, SNMP and HTTP are all enabled with default passwords. To ensure security, change the passwords or disable the protocols.

To change the passwords for SSH, Telnet and HTTP use the **gsyspasswd** command. To change the passwords/community strings for SNMP see *Appendix C - SNMP*.

To disable Telnet use the **inetdconfig** command. To disable SSH, SNMP and HTTP see *Appendix D - Security*.

## Connecting Instruments to the Meridian

Rear-panel mounted BNC jacks provide the means of connecting your equipment to the Meridian. The standard Meridian provides two precision output signals capable of driving properly terminated coaxial cables: 1PPS and AM Code. These two signals are DC-coupled and sourced from Advanced CMOS (ACMOS) drivers which are able to maintain output TTL levels into a 50-ohm load. The optional low-phase noise, spectrally pure sinewave outputs are capable of driving 1 Vrms into a 50-ohm load. If your unit is equipped with other optional timing or frequency outputs, these will also be designed to drive a 50-ohm load. Care should be taken not to short circuit these outputs or to connect them to other voltage sources.

If your unit is equipped with the optional Alarm Output, it will be available on a rear-panel BNC jack labeled “ALARM”. Care should be taken not to directly connect this open-collector output to a voltage source. A series current-limiting resistor of at least 1K ohms in value should be used. The pull-up voltage must not exceed 40V.

If your primary application for the Meridian is as a frequency standard and you have not purchased one of the optional higher-stability oscillators, you should consider operating with the display set to view the Receiver State. (See *Chapter 3 - Front-Panel Keypad and Display*.) With this display in view you will always know whether the Meridian is currently locked to a CDMA signal while you are performing measurements based on its frequency outputs. The holdover frequency accuracy of the standard TCXO will degrade to the  $5 \times 10^{-8}$  level fairly quickly following CDMA signal loss, depending upon the ambient temperature.

Refer to *Chapter 6 - Rear-Panel Output Options* and to *Appendix L - Specifications* for more information on the rear-panel output signals.

# Chapter Three

## Front-Panel Keypad and Display

*This section describes the Meridian front-panel user interface which consists of a graphic vacuum-fluorescent display (VFD) and keypad. The keypad and display provide a convenient interface that allows the user to quickly check the operation of the instrument and setup many control parameters. If desired, the Network Administrator can disable the keypad EDIT key to prevent unauthorized tampering with the instrument setup. Even when disabled, all status and control parameters are available for reading only.*

### Display Description

The display consists of a graphic 16 x 280 dot-matrix vacuum-fluorescent array. The VFD technology offers very readable alphanumeric characters with variable font sizes. Time information is readable at distances in excess of 15 feet. The keypad consists of an eight-key switch assembly designed to allow easy parameter selection and control.

### Keypad Description

The front-panel keypad consists of eight switch keys identified as follows:

<b>ENTER:</b>	Select a menu item or load a parameter when editing.
<b>BACK:</b>	Return to previous display or abort an edit process.
<b>EDIT:</b>	Edit the parameter currently in view.
<b>HELP:</b>	Display context-sensitive help information.
<b>LEFT arrow:</b>	Select a new item to the left.
<b>RIGHT arrow:</b>	Select a new item to the right.
<b>DOWN arrow:</b>	Scroll through parameter values in edit displays or through help lines in help displays. In all other displays this key has a secondary function where it will operate like the ENTER key to select menu items.
<b>UP arrow:</b>	Scroll through parameter values in edit displays or through help lines in help displays. In all other displays this key has a secondary function where it will operate like the BACK key to return to the previous display.

## Display and Keypad Operation

The display is organized like the inverted tree structure shown below:

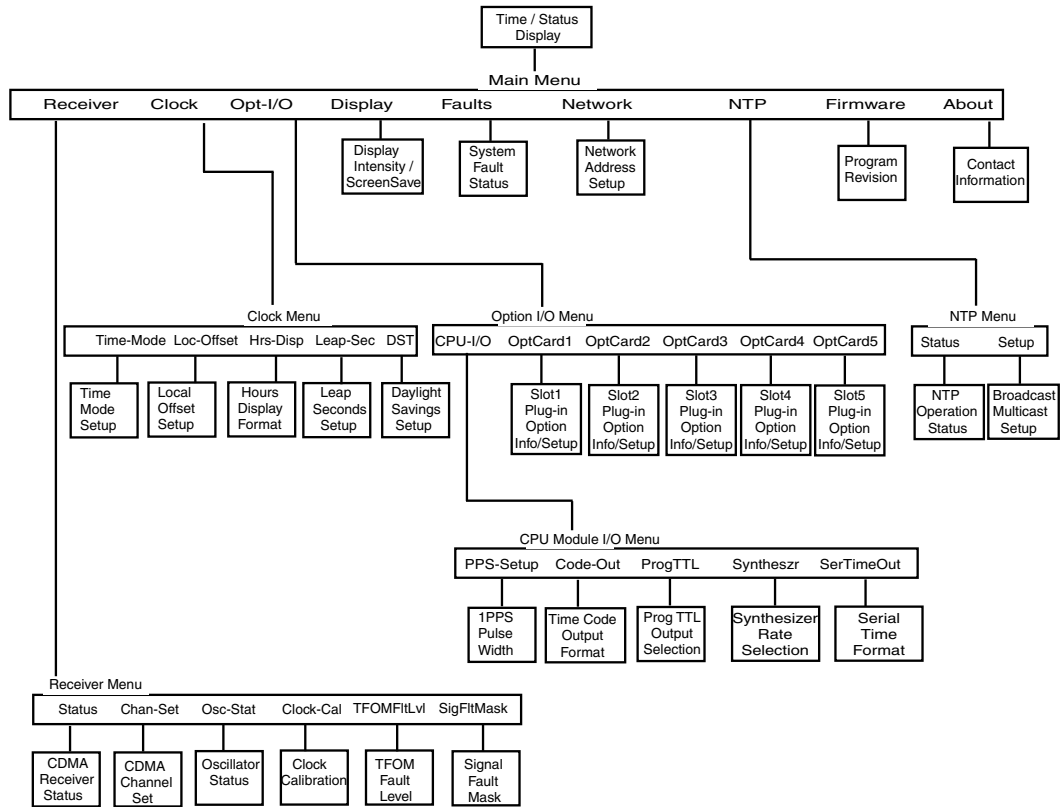

### Traversing the Display Structure

After power initialization the welcome message will appear. Press any key to go to the Time/Status display, which is described under the heading *Detailed Display Descriptions*. From the Time/Status display, press ENTER (or DOWN arrow) to go to the Main Menu. As illustrated in the diagram above, several status and setup displays are accessible from the Main Menu. To traverse downward through the tree use the RIGHT and LEFT arrow keys to highlight a selection and then press ENTER. To traverse back up the tree press BACK (or UP arrow) to return to the previous display.

### Editing

To modify a parameter, traverse to the appropriate display and push EDIT. This will cause the edit display to appear. Within the edit display, the modifiable parameter value is highlighted. Use UP and DOWN to scroll through all the possible parameter values. When editing a sequence of numbers, use LEFT and RIGHT to select other digits. When the parameter is correct, press ENTER to load the new value. All entered values are stored in non-volatile FLASH and restored after a power cycle. If you wish to abort the edit process, press BACK. This operation returns you to the previous display and the parameter will remain unchanged.

**Keypad EDIT Lockout**

As a security feature, the Network Administrator can disable all editing processes done through the front-panel keypad. This action should be performed to prevent unauthorized modification of the instrument. When the EDIT key has been disabled, a warning message will appear whenever a user tries to edit a parameter. To enable the lockout feature use the **lockoutkp** command as described in *Chapter 4 - Control and Status Commands*. The lockout feature will prevent editing only, the displays are always available for viewing.

**Using Help**

Press HELP at any time to read the context-sensitive help messages. Most Help messages have much more information than can be viewed within the two-line display. Use UP and DOWN to scroll through the help message. Press the HELP key a second time to exit Help (or press BACK).

**Shortcut Menu**

The Shortcut Menu allows the user quick access to particular displays from the Time/Status display. The displays available through the Shortcut Menu are the Receiver Status display, the Faults display, and the NTP Status display. To select the Shortcut Menu, press ENTER for one second while viewing the Time/Status display.

**Detailed Display Descriptions**

The Time/Status display provides all the information necessary to determine that the instrument is working correctly:

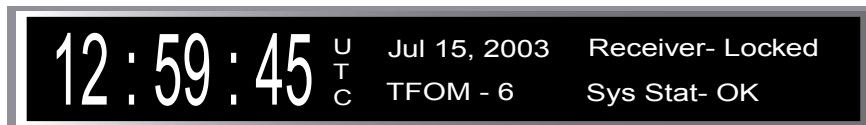

- Time-of-Day: The large numeric digits shown on the left side of the display indicate the current time-of-day.
- Time Mode: The indicator next to the time digits identifies the time mode as being UTC, GPS or LOC (for local time). If the user selects local time in the 12-hour mode, an AM or PM indicator will appear instead of LOC.
- Date: Current month, day and year.
- TFOM: A detailed explanation of TFOM is in *Appendix A - Time Figure-of-Merit*. Briefly, TFOM indicates clock accuracy where:
  - 6 time error is < 100 us
  - 7 time error is < 1 ms
  - 8 time error is < 10 ms
  - 9 time error is > 10 ms, unsynchronized state if never locked to CDMA.
- Receiver Status: CDMA receiver status as follows:
  - Acquire: Searching for a signal.
  - Detect: A signal is detected.
  - Locking: Locking to the Pseudonoise (PN) Code.

Tracking: Locking to the carrier.  
 Locked: Fully synchronized to signal.

System Status: Indicates either OK or flashing FAULT. A fault status indicates that one or more of the built-in fault checking processes has detected an error condition. See *Faults Display* in this chapter for more information.

An alternate Time/Status display can be viewed by pressing the right arrow key. You can go back to the original Time/Status display by pressing the left arrow key.



**Main Menu**

Press ENTER from the Time/Status display to select the Main Menu display. The Main Menu provides access to the following displays: *Receiver*, *Clock*, *CPU-I/O*, *Display*, *Faults*, *Network*, *NTP*, *Firmware*, and *About*. To select one of these items use the RIGHT and LEFT keys to highlight it. Then push ENTER to select the highlighted item. These displays are described in detail below.

**Receiver Menu**

The Receiver Menu is selected from the Main Menu and provides access to the Receiver Status, Channelset and Oscillator Status displays described below.

**Receiver Status**

This display provides information associated with the operation of the CDMA receiver. Press DOWN to scroll through all the information.

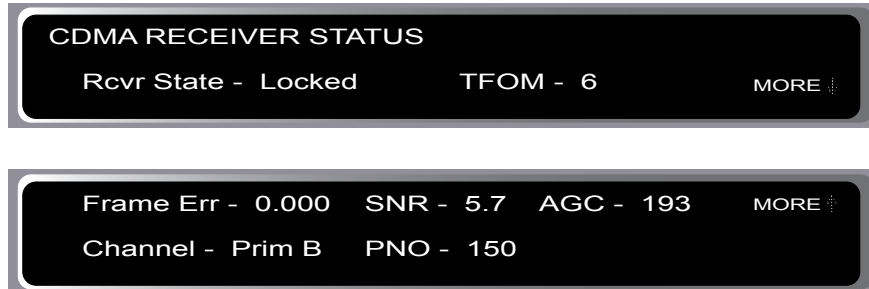

Receiver State: This shows the current state of the CDMA Subsystem. The state may be: acquire, detect, locking, tracking, or locked. When locked, the CDMA receiver is synchronized to the signal and it is disciplining the internal oscillator to remove frequency and time errors.

TFOM: A detailed explanation of TFOM is in *Appendix A - Time Figure-of-Merit*. Briefly, TFOM indicates clock accuracy where:

- 6 time error is < 100 us
- 7 time error is < 1 ms
- 8 time error is < 10 ms
- 9 time error is > 10 ms, unsynchronized state if never locked to CDMA.



Frame Err:	The number shown represents the sync channel frame error rate, 0.000 to 1.000, with a higher number implying more Cyclical Redundancy Check (CRC) failures. Higher numbers will correlate with lower signal-to-noise ratios.
SNR:	The signal-to-noise ratio is an indicator of the CDMA signal quality. This number must typically be greater than 2.5 for the instrument to acquire, but it will maintain lock at levels down to about 2.0.
AGC:	This is the automatic gain control DAC byte, 0 to 255, with larger numbers implying higher RF gain. With good signal conditions this value is typically 150 to 220.
Channel:	This is the CDMA frequency channel being used. There are eight possible cellular channels and 42 possible PCS channels. Units configured for operation in Japan have two possible cellular channels.
PNO:	This is the pseudonoise offset, 0 to 511 in units of 64 pseudonoise code chips. Each base station in an area has a different PNO.

**Channelset**

This display shows the current CDMA channelset being used by the CDMA Subsystem. It also allows setting of the channelset to one of: North America Cellular, Korea Cellular, India Cellular, and North America PCS. Units configured for operation with the Japanese Cellular channelset will not have this capability.

**Oscillator Status**

This display provides the oscillator type, electronic frequency control status and several oscillator disciplining parameters. The oscillator type indicates the oscillator that is installed. Possible oscillator types are:

- Temperature-compensated crystal oscillator (TCXO)
- Medium-stability oven oscillator (MS-OCXO)
- High-stability oven oscillator (HS-OCXO)
- Ultra-High Stability oven oscillator (US-OCXO)
- Rubidium oscillator (Rb)
- High-Stability Rubidium oscillator (HS-Rb)

Osc Cntrl DAC:	The oscillator control DAC value indicates the frequency control setting. The system automatically sets this value to remove frequency errors. Values may range from 0 to 1048575. Values close to the maximum/minimum settings will set the DAC fault flag that will appear in the fault status display. The Time/Status display will also indicate a fault condition.
Coast Time:	This indicates the number of seconds the unit has been in coast mode.
Estimated Time Error:	This is the estimated time error of the instrument while in coast mode.
Measured Time Error:	This is the last measured time offset while locked.

Time Deviation:	Time deviation of measurements.
Ageing Rate:	Regression computed oscillator ageing rate per day.
Control Loop TAU:	Control loop averaging time constant.
Temperature:	The internal temperature (OCXO and Rubidium oscillators only).

**Clock Calibration**

Use Clock Calibration to set the antenna propagation delay. This will advance or retard the clock in order to correct for antenna cable length or to compensate for the inherent time offsets that may exist with external hardware such as distribution amplifiers, etc. Clock Calibration range is  $\pm 500.000$  microseconds.

**TFOM Fault Level**

The TFOM Fault Level is the threshold at which a signal loss fault will be asserted. See *Appendix A - Time Figure of Merit* for more information. The factory default for the TFOM Fault Level is 9, which is also the maximum TFOM value. By changing the TFOM Fault Level you control the point at which the time error will produce a signal loss fault, which then creates an alarm condition.

**Signal Loss Fault Mask**

This setting allows you to prevent a signal loss fault from creating an alarm condition. Some installations may need to mask this fault when operating the NTP server as a Stratum 2 server.

**Clock Menu**

The Clock Menu provides access to the parameters related to timekeeping. These are Time Mode, Local Offset, Hours Format, Leap Seconds, and Daylight Savings Time. These displays are all described below.

**Time Mode**

Time mode defines the time format used for the front-panel time display and, if installed, the optional time code output or Serial Time output. The time mode does not affect the NTP output, which is always UTC. Possible values for the time mode are GPS, UTC, and local time. GPS time is derived from the GPS satellite system. UTC is GPS time minus the current leap second correction. Local time is UTC plus local offset and Daylight Savings Time (DST). The options for local time are local-auto and local-manual. Local-auto derives the local offset and DST from the information embedded in the CDMA timing signal. Local-manual derives the local offset and DST from information entered by the user. The local offset and daylight savings time displays are described below.

**Local Offset**

Local offset is used in calculating the current local time when the time mode is set to local (see time mode above). When the time mode is local-auto this display will show the local offset as derived from the CDMA timing information. When the time mode is local-manual, this display will allow the user to change the value by pressing EDIT. Enter a negative offset for time zones west of the Greenwich meridian, and a positive offset for time zones to the east. If enabled, DST will add an additional hour.

**Hours Display**

The hours-display format affects the front-panel time display and is active only when the time mode is set to local time. Hours-display selections are either 12-hour format (1-12 hours with AM/PM indicator) or 24-hour format (0-23 hours).

### Leap Seconds

Leap seconds affect NTP, UTC and Local Time (not GPS Time). Leap second insertions occur about once every two years. The Meridian has two different modes for handling leap seconds. In automatic leap second mode, this display will show the current and future leap seconds as broadcast over the CDMA system.

In user-entered leap second mode, this display shows the user-entered current and future leap second values. Press EDIT to change these values.

The Meridian is shipped from the factory set for the user-entered mode with current and future leap seconds set appropriately. You will need to change this setting the next time a leap second is pending. Refer to *Appendix H - Leap Seconds* for further information.

### Daylight Savings Time

Daylight Savings Time (DST) is used in calculating the current local time when the time mode is set to local-manual. When the time mode is local-auto this display has no effect because DST information is derived from the CDMA system. When the time mode is local-manual this display will allow the user to enable or disable DST by pressing EDIT. If DST is disabled then any previously set start and stop times will be ignored. If DST is enabled then the start and stop times can be set by pressing the arrow keys to scroll and then ENTER. DST is active within the start-stop interval and adds one hour to the local time. If DST is active the display will show an active indicator.

### CPU I/O Menu

The CPU I/O Menu is an optional menu selected from the Main Menu. It provides access to the 1PPS Output pulse width, AM Code Output (time code) format, and Programmable TTL Output setting. This menu will only be displayed if one of these optional outputs is installed.

### 1PPS Output Setup

The optional 1PPS-Setup display allows you to select the pulse width for the 1PPS Output. Factory default is normally 1 millisecond wide. See details in *Appendix L - Specifications* for the 1PPS Output.

### Time Code Output Setup

The optional Code-Out display allows you to select the time code format. Factory default is normally IRIG-B122. See details in *Appendix L - Specifications* for the AM Code Output.

### Programmable TTL Output Setup

The optional Programmable TTL Output provides user-selectable, on-time pulse rates from 1PPS to 10MPPS, or a digital time code. This display will allow you to choose from among the various selections. Factory default is normally 10MPPS. See details *Appendix L - Specifications* for the Programmable TTL Output.

### Synthesizer (DDS) Setup

The optional Synthesizer display allows you to select the rate for the Direct Digital Synthesizer (DDS) Output. See details in *Appendix L - Specifications* for the Optional Programmable TTL Output (Synthesized Rate).

### Serial Time Output Setup

The optional Serial Time Output display allows you to set up the parameters for the once-per-second, serial time output. Format, baud rate and parity are all user-selectable. See details in *Chapter 6 - Optional Rear-Panel Outputs*.

**Display Setup**

This display is selected from the Main Menu and contains parameters related to the functioning of the front-panel vacuum-fluorescent display. There are two parameters -- an intensity setting and a screensaver setting. The intensity setting allows you to set the brightness level of the vacuum-fluorescent display. Display intensity ranges from 12% to 100%. The screensaver capability allows you to increase the usable life of the display beyond the rated 100,000 hours. When the screensaver capability is enabled, the intensity will be reduced to half of its normal operating intensity when the unit has not detected a keypress for one hour. Press EDIT to modify the intensity and screensaver settings.

**Faults**

This display is selected from the Main Menu and provides system fault information. When a particular fault condition is asserted it will be followed by a flashing indicator. Otherwise the fault condition is followed by an "ok" indicator. The fault display and various fault conditions are described below:

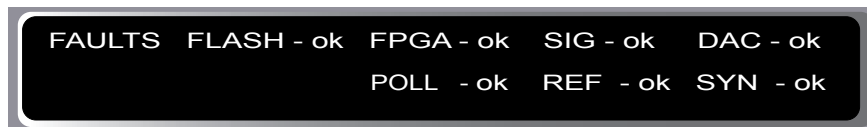

- FLASH**    FLASH Write - This fault indicates that the microprocessor was unable to verify a write to the FLASH non-volatile parameter storage area. This should not ever occur under normal operation. This fault would cause erratic operation at the next power cycling since important parameters could be corrupt. The unit should be returned to the factory for repair.
- FPGA**    FPGA Configuration - This bit indicates that the microprocessor was unable to configure the FPGA. This would be a fatal fault and the unit should be returned to the factory for repair.
- SIG**      No Signal Time-Out - This bit indicates that the unit has not been able to acquire a CDMA signal for one hour while the Time Figure of Merit has been greater than or equal to the TFOM Fault Level (see the Receiver Menu > TFOM Fault Level). This could be due to a variety of reasons. If there are no other faults that could explain the inability to receive a signal, then there could be an antenna blockage. If the condition persists indefinitely, the unit may need to be returned to the factory for repair.
- DAC**      DAC Control Over-Range - This bit indicates that the electronic frequency control DAC for the oscillator has reached either the high (55000) or low (10000) limit while locked to the CDMA signal. Unless the unit is being subjected to out-of-specification environmental conditions, this would indicate that the oscillator frequency has drifted near to the end-of-life region. This should normally only occur after about ten years of operation. The unit will continue to function until the oscillator frequency finally reaches one of the actual DAC endpoints. The unit should be returned to the factory for oscillator replacement at the customer's convenience.
- POLL**    No Polling Events - This fault indicates that the CDMA Subsystem is not receiving polling requests from the Linux Subsystem. This could be due to a hardware or software failure. If the condition persists after cycling the power to the unit, this is a fatal fault and the unit should be returned to the factory for repair.

- REF Time Reference - This fault indicates that the microprocessor has received an erroneous time input from the CDMA receiver. Do NOT do a power cycle in an attempt to clear this fault. If the condition persists please report it to the factory (1-877-749-3878).
- SYN Synthesizer Fault - This fault indicates that the Local Oscillator Phase Locked Loop (PLL) synthesizer has failed. This condition should not normally occur unless the unit is subjected to out-of-specification environmental conditions. This is a fatal fault and the unit should be returned to the factory for repair.
- PWRA Power Supply A - This indicator is only used if your Meridian is configured with dual redundant power supplies. The primary power supply (A) is constantly monitored whether it is supplying the internal chassis power or not. PWRA indicates a failure.
- PWRB Power Supply B - This indicator is only used if your Meridian is configured with dual redundant power supplies. The secondary power supply (B) is constantly monitored whether it is supplying the internal chassis power or not. PWRB indicates a failure.

#### **Network4 Setup**

This display is selected from the Main Menu and provides the ability to view and modify the IPv4 network settings. The parameters include Dynamic Host Configuration Protocol (DHCP), IP address, gateway and netmask settings. Enable DHCP to allow automatic system configuration of the network interface. When DHCP is disabled the user must provide address information.

#### **Network6 Setup (Optional)**

This display is only available if your Meridian has been configured with IPv6. It is selected from the Main Menu and provides the ability to view and modify the IPv6 network settings. Refer to *Appendix I - IPv6 Information*.

#### **NTP Menu**

The NTP Menu is selected from the Main Menu and provides access to the NTP Status and NTP Setup displays described below:

##### **NTP Status**

This display provides information associated with the NTP subsystem.



- Stratum: This stratum field has three possible values:
- Stratum 1: The server is fully synchronized and accurate.
  - Stratum 2: The server is synchronized to a stratum 1 server with IP address shown in Source.
  - Stratum 16: The server is unsynchronized. NTP clients will not use a Stratum 16 server.
- Source: The synchronization source is named here. For the Meridian CDMA the source is CDMA, IP address of upstream source, or none.

- Offset:** The NTP offset indicates the accuracy of the NTP system clock relative to the CDMA Subsystem clock. Initially, if the offset between the NTP system clock and the CDMA Subsystem clock is large the display will indicate “not available”. After the CDMA Subsystem locks, the NTP clock will synchronize to the CDMA Subsystem. Once synchronization is complete, the typical offsets will range over approximately +/- 1 microsecond.
- LI Bits:** Shows the status of the leap indicator bits as sent by the Meridian time server to the clients in the NTP reply packets. Descriptions of the leap indicator are:
- 00 - None: No fault and no pending leap second.
  - 01 - Insert Pending: No fault and a leap second insertion is pending.
  - 10 - Delete Pending: No fault and a leap second deletion is pending.
  - 11 - Fault: Unsynchronized fault condition exists.

**NTP Setup**

This display provides access to the NTP broadcast and multicast settings and provides the user with a convenient means of checking the current configuration and allows limited setup. You may also perform a more complete broadcast/multicast configuration via a **telnet** or **ssh** session or the local RS-232 console using the **ntpconfig** utility. This utility provides a more secure means of setup and so is more complete. It will allow you to select keys and identify trusted keys.

This display will indicate that the mode is broadcast, multicast, or disabled. It allows either broadcast or multicast configuration with selection of the broadcast address, multicast time-to-live (TTL) and trusted key for MD5 authentication. The broadcast/multicast mode may also be disabled.

- Broadcast Mode** In this mode the broadcast address is displayed. If MD5 authentication is selected the trusted key number will also be displayed.
- Multicast Mode** The multicast address must be 224.0.1.1. The TTL value is the number of router hops that multicast traffic is permitted to pass through before expiring on the network. Multicast may also use MD5 authentication. If selected, the trusted key number will also be displayed.

Press EDIT to change the broadcast/multicast settings. Each of the edit windows has help information available to guide you through the setup process. Note that changing the NTP multicast/broadcast settings does not take effect until the system reboots. The new parameters are loaded to the *ntp.conf* file in the */boot/etc/* directory. Only the broadcast line in the *ntp.conf* file is modified. The final display in the edit sequence requires confirmation of your intent to change the instrument settings. Once confirmation takes place, the instrument will reboot.

**PTP Menu (Optional)**

The PTP Menu is available only if the PTP/IEEE-1588 option has been enabled in your Meridian. For further information see *Appendix K - Precision Time Protocol/IEEE-1588*.

**Firmware**

The Firmware display is selected from the Main Menu and provides version information for the application software running on the CDMA Subsystem and the Linux Subsystem (root file system and kernel). Use UP and DOWN to toggle between the information windows.

**About**

The About display is selected from the Main Menu and provides contact information for EndRun Technologies. The website and toll-free phone number are listed.





# Chapter Four

## *Control and Status Commands*

---

*This chapter describes the Meridian control and status commands. The Meridian supports several application-specific commands for performing initialization/setup and for monitoring the performance and status of the unit. You do not need knowledge of Linux commands in order to operate the Meridian. However, the Meridian does support a subset of the standard Linux shell commands and utilities. A wealth of information is available from a variety of sources on Linux. Only the Meridian-specific commands will be described in this chapter. The serial I/O port physical and electrical characteristics are defined as well.*

### **General Linux Shell Operation**

You do not need to know Linux in order to operate the Meridian. However, for those interested, the command shell used by the Meridian is the Linux standard: **bash**. All commands and file names are case sensitive, which is standard for Unix-like operating systems. If you are unfamiliar with Unix-like operating systems, and you would like to be able to more closely monitor or optimize the performance of your Meridian you should consult either the web at:

<http://www.tldp.org>

Or good Linux reference books like:

*Linux in a Nutshell*, Seiver, O'Reilly & Associates, 1999.

*Running Linux*, Welsh, Dalheimer & Kaufman, O'Reilly & Associates, 1999

## Available User Commands

COMMAND	FUNCTION
accessconfig	Interactive shell script that guides the user in configuring <b>telnet</b> , <b>ssh</b> and <b>snmpd</b> access to the Meridian that is limited to specific hosts. The resulting <i>/etc/hosts.allow</i> and <i>/etc/hosts.deny</i> files are saved to the non-volatile FLASH disk. Factory default configuration allows access by all hosts.
cdmacaldelay	Prints the calibration delay to the console.
cdmachannelset	Prints the current CDMA channelset being used. It can be one of North American Cellular, South Korean Cellular, North American PCS, India Cellular or Japanese Cellular.
cdmaleapconfig	Guides the user in configuring the way in which UTC leap seconds are handled: either automatically via CDMA basestation transmissions or by user-entered current and future leap second parameters.
cdmaleapmode	Prints the current CDMA leap second mode of operation, either automatic or user-entered. If user-entered, prints the current and future leap second values.
cdmastat	Prints the CDMA Subsystem status information to the console.
cdmaversion	Prints the CDMA firmware and FPGA version information to the console.
cptpstat (optional)	Prints the status of the optional PTP/IEEE-1588 subsystem.
cpuopts	Returns the current settings for any installed, user-selectable outputs from the CPU Module. These are 1PPS, AM Code and the optional Programmable TTL Output.
cpuoptsconfig	An interactive script that allows the user to modify the settings for the CPU Module outputs listed above.
cpusertime	Prints the current settings for the optional Serial Time Output.
cpusertimeconfig	An interactive script that allows the user to modify the settings for the optional Serial Time Output.
csyshwaddr	Prints the ethernet hardware address, if the ethernet has been configured.
csysostype	Prints the installed oscillator type.
csyspasswd	Allows the <i>root</i> user to change the password for the two configured users on the Meridian: <i>csysuser</i> and <i>root</i> . This script calls the standard Linux <b>passwd</b> binary and then saves the resulting <i>/etc/shadow</i> file to the non-volatile FLASH disk.
csysrootfs	Prints the current root file system image, either MeridianCDMA_0 (factory default) or MeridianCDMA_1 (field upgrade) which is running in the Meridian to the console.
csysstat	Parses the output of <b>ntpq -c peers</b> to obtain the system peer status of the NTP CDMA reference clock. It also retrieves the current reference clock polling status data and prints it to the console.

## CONTROL AND STATUS COMMANDS

cssystemmode	Prints the time mode settings in effect for the AM Code Output (time code) or Serial Time Output.
cssystemmodeconfig	Interactive shell script that guides the user in configuring the time mode settings for the time code output or Serial Time Output. Allows setting to the local, GPS or UTC timescale. If local-manual is selected, then the allows configuration of the local offset and Daylight Savings Time (DST) start/stop date parameters.
cssystemversion	Prints the Linux Subsystem software version information to the console.
eraserootfs_1	Command to erase the UPGRADE root file system FLASH partition. This must be executed prior to loading the new file system image during the Linux upgrade process.
help	Prints help for Meridian commands (not Linux).
inetdconfig	Interactive shell script that allows the user to configure the list of protocol servers which are started by the <b>inetd</b> server daemon running in the Meridian.
kplockstat	Prints the front-panel keypad lockout status.
lockoutkp	Locks out access to the front-panel keypad EDIT key.
netconfig	Interactive shell script that allows the user to configure the IP network subsystem of the Meridian.
ntpconfig	Interactive shell script that guides the user in configuring the Meridian NTP subsystem. Allows configuration of MD5 authentication and broadcast/multicast mode. All parameters are retained in non-volatile FLASH disk storage.
oscctrlstat	Prints the oscillator disciplining parameters.
pluginopts	Returns the board type and settings for any optional buffer boards. (In Meridian products these options are not “plug-in” but must be installed at the factory.)
pluginoptsconfig	An interactive script that allows the user to change the settings on any configurable option board.
ptpconfig ptp2config (optional)	Interactive shell script that guides the user in configuring parameters for the optional PTP/IEEE-1588 protocol..
ptpversionconfig (optional)	Interactive shell script that guides the user in selecting either PTP/IEEE-1588 version 1 or version 2.
setcdmacaldelay	An interactive script that allows the user to change the clock calibration delay.
setcdmachannelset	Command that allows the user to select the channelset for the CDMA Subsystem to receive. This command is not functional in units configured for Japanese Cellular operation.
setsigfltmask	Command to mask or enable the Signal Loss Fault.
settfomfltlvl	Command to change the TFOM Fault Level.
sigfltmask	Prints the current setting for the TFOM Fault Level.
tfomfltlvl	Prints the current setting for the TFOM Fault Level.
unlockkp	Unlocks access to the front-panel keypad EDIT key.

updaterootflag	Command to update the flag stored in FLASH that is read by the Linux bootloader at boot time to select operation with either the FACTORY or UPGRADE root file system.
upgradedcdma	Shell script that facilitates the CDMA Subsystem firmware upgrade process.
upgradekernel	Shell script that facilitates the Linux kernel firmware upgrade process. Limited applicability. Use with caution.

## Detailed Command Descriptions

### **accessconfig**

This command starts an interactive shell script that will allow the root user to configure limitation of **telnet**, **ssh** and **snmp** access to the Meridian. By default, the unit is configured to allow access by all users. If you need to limit **telnet**, **ssh** or **snmp** access, e.g. for security reasons, you must run this script as root from either the RS-232 serial I/O port or from a **telnet** or **ssh** session.

This script modifies these files: */etc/hosts.allow* and */etc/hosts.deny*. These are non-volatilely stored in the FLASH disk */boot/etc* directory. You must reboot the Meridian after running this script for the changes to take effect.

Set: **accessconfig**  
 Meridian response: Interactive shell script is started.

### **cdmacaldelay**

This command displays the current calibration delay setting. The allowable calibration delay range is +500000 to -500000 nanoseconds.

Query: **cdmacaldelay**  
 Meridian response: +0 nanoseconds

### **cdmachannelset**

This command displays the CDMA channelset currently being used by the CDMA Subsystem. It can be one of: North American Cellular, South Korean Cellular, North American PCS, Indian Cellular, or for certain units, Japanese Cellular.

Query: **cdmachannelset**  
 Meridian response: **Channelset is North American PCS**

### **cdmaleapconfig**

Leap seconds affect NTP, UTC and Local Time (not GPS Time). Leap second insertions occur about once every two years. This command starts an interactive shell script that will guide the root user in configuring the way that UTC leap seconds are handled.

There are two different modes for handling leap second insertions: automatic and user-entered. The Meridian is shipped from the factory in user-entered leap second mode with the current and future

leap second values set appropriately. You will need to change these values the next time a leap second is pending. The interactive script is very detailed in explaining how these values are obtained and used. There is also more information in *Appendix H - Leap Seconds*.

Query: **cdmaleapconfig**  
Meridian response: Interactive shell script is started.

**cdmaleapmode**

This command displays the CDMA leap mode of operation currently configured. There are two modes: automatic and user-entered. If the mode is user-entered, then the values of the configured current and future leap seconds are also displayed.

Query: **cdmaleapmode**  
Meridian response:  
**CDMA Leap Second Mode is USER: Current LS = 13, Future LS = 13**

**cdmastat**

This command allows the user to query the status of the CDMA Subsystem. During normal operation, the NTP daemon polls the CDMA Subsystem every 16 seconds. The results of this poll are used to steer the system clock and are saved to a log file. This command parses and formats the information contained therein and prints this fixed-length string having these fields:

```
LKSTAT TFOM = ? YEAR DOY HH:MM:SS.ssssssss LS S C PNO AGC VCDAC SN.R F.ERR FLTS
```

Where:

LKSTAT is the tracking status of the CDMA Subsystem, either LOCKED or NOTLKD.

TFOM = ? A detailed explanation of TFOM is in *Appendix A - Time Figure-of-Merit*. Briefly, TFOM indicates clock accuracy where:

- 6 time error is < 100 us
- 7 time error is < 1 ms
- 8 time error is < 10 ms
- 9 time error is > 10 ms, unsynchronized state if never locked to CDMA.

YEAR is the year of the UTC timestamp of the most recent information received from the CDMA Subsystem.

DOY is the day-of-year of the UTC timestamp of the most recent information received from the CDMA Subsystem.

HH:MM:SS.ssssssss is the hour, minute, second.subsecond UTC timestamp of the most recent polling request received from the CDMA Subsystem.

LS is the current number of leap seconds difference between the UTC and GPS timescales (13 at the time of this writing).

- S** is the signal processor state, one of 0 (Acquiring), 1 (Signal Detected), 2 (Code Locking), 4 (Carrier Locking), 8 (Locked).
- C** is the CDMA frequency channel being used, one of 0 thru 61, depending upon the channelset being used:  
For North American Cellular these are:  
0 (Primary A), 1 (Primary B), 2 (Secondary A), 3 (Secondary B)  
For South Korean Cellular these are:  
4 (Primary A), 5 (Primary B), 6 (Secondary A), 7 (Secondary B)  
For North American PCS these are:  
8 (00 A), 9 (01 A), 10 (02 A), 11 (03 A), 12 (04 A), 13 (05 A), 14 (06 A), 15 (07 A),  
16 (08 A), 17 (09 A), 18 (10 A),  
19 (00 D), 20 (01 D), 21 (02 D) ,  
22 (00 B), 23 (01 B), 24 (02 B), 25 (03 B), 26 (04 B), 27 (05 B), 28 (06 B), 29 (07 B),  
30 (08 B), 31 (09 B), 32 (10 B)  
33 (00 E), 34 (01 E), 35 (02 E)  
36 (00 F), 37 (01 F), 38 (02 F)  
39 (00 C), 40 (01 C), 41 (02 C), 42 (03 C), 43 (04 C), 44 (05 C),  
45 (06 C), 46 (07 C), 47 (08 C), 48 (09 C), 49 (10 C).  
For Japanese Cellular these are:  
50 (Primary A), 51 (Secondary A).  
For India Cellular these are:  
52 (Sri Lanka 43), 53 (Sri Lanka 146),  
54 (India 185), 55 (India 226), 56 (India 267), 57 (India 308),  
58 (India 369), 59 (India 410), 60 (India 451), 61 (India 492).
- PNO** is the base station pseudonoise offset, 0 to 511 in units of 64 pseudonoise code chips.
- AGC** is the automatic gain control DAC byte, 0 to 255 with larger numbers implying higher RF gain. Typical range is 150 to 220.
- VCDAC** is the TCXO voltage control DAC word, 0 to 1048575 with larger numbers implying higher TCXO frequency. Typical range is 320000 to 640000.
- SN.R** is the carrier signal-to-noise ratio, 0.00 to 99.9, measured in the CDMA sync channel symbol rate bandwidth. Typical range is 2.5 to 11.0.
- F.ERR** is the CDMA sync channel frame error rate, 0.000 to 1.000, with a higher number implying more Cyclical Redundancy Check (CRC) failures when processing the sync channel message frames. Higher numbers will correlate with lower signal-to-noise ratios.
- FLTS** is the fault status, which displays the current summary status of the CDMA Subsystem. The summary status is contained in sixteen bits which are displayed in four

---

## CONTROL AND STATUS COMMANDS

hexadecimal characters. Assertion of any of these bits will also be indicated by illumination of the red LED. Each bit of each character indicates the status of a subsystem component:

	Bit 3	Bit 2	Bit 1	Bit 0
Char 0	FLASH Write Fault	FPGA Config Fault	No Signal Time-Out	DAC Control Over-Range
Char 1	Not Used	No Polling Events	Time Input Fault	Local Osc Fault
Char 2	Not Used	Not Used	Power B Fault	Power A Fault
Char 3	Not Used	Not Used	Not Used	Not Used

*DAC Control Over-Range:* This bit indicates that the electronic frequency control DAC for the oscillator has reached either the high (55000) or low (10000) limit while locked to the CDMA signal. Unless the unit is being subjected to out-of-specification environmental conditions, this would indicate that the oscillator frequency has drifted near to the end of life region. This should normally only occur after about ten years of operation. The unit will continue to function until the oscillator frequency finally reaches one of the actual DAC endpoints. The unit should be returned to the factory for oscillator replacement at the customer's convenience.

*No Signal Time-Out:* This bit indicates that the unit has not been able to acquire a CDMA signal for one hour while the Time Figure of Merit has been greater than or equal to the TFOM Fault Level. This could be due to a variety of reasons. If there are no other faults that could explain the inability to receive a signal, then there could be an or antenna failure or blockage. If the condition persists indefinitely, and a problem with the antenna is not evident, the unit may need to be returned to the factory for repair.

*FPGA Config Fault:* This bit indicates that the microprocessor was unable to configure the FPGA. This would be a fatal fault and the unit should be returned to the factory for repair .

*FLASH Write Fault:* This bit indicates that the microprocessor was unable to verify a write to the FLASH non-volatile parameter storage area. This should not ever occur under normal operation. This fault would cause erratic operation at the next power cycling since important parameters could be corrupt. The unit should be returned to the factory for repair.

*Local Oscillator Fault:* This bit indicates that the receiver Local Oscillator Phase Locked Loop (PLL) synthesizer is either unlocked or has failed. This condition should not normally occur unless the unit is subjected to out-of-specification environmental conditions. Otherwise, this would be a fatal fault and the unit should be returned to the factory for repair (1-877-749-3878).

*Time Input Fault:* This bit indicates that the microprocessor received an erroneous time input from the CDMA Subsystem. Do NOT do a power cycle in an attempt to clear this fault. If the condition persists please report it to the factory.

*No Polling Events:* This bit indicates that the CDMA Subsystem is not receiving polling requests from the Linux Subsystem. This could be due to a hardware or software failure. If the condition persists after cycling the power to the unit, this is a fatal fault and the unit should be returned to the factory for repair.

*Power A Fault:* This bit is only used if the Meridian is configured with dual redundant power supplies. It indicates the operational status of the primary supply regardless of whether it is supplying the internal chassis power.

*Power B Fault:* This bit is only used if the Meridian is configured with dual redundant power supplies. It indicates the operational status of the secondary supply regardless of whether it is supplying the internal chassis power.

The example response indicates that there has been a period without tracking a CDMA signal that exceeded the time-out period, that there was a FLASH Write Fault and that there is a Local Oscillator PLL fault.

```
Query:                cdmastat
Meridian response:
LOCKED TFOM = 6 2001 092 04:48:56.347916732 13 8 1 132 28605 8.6 0.000 001A
```

#### **cdmaversion**

This command displays the firmware and hardware versions of the CDMA Subsystem.

```
Query:                cdmaversion
Meridian response:    F/W 1.00 FPGA 0202
```

#### **ctptstat (Optional)**

This command is only available if the PTP/IEEE-1588 option has been installed. Refer to *Appendix K - Precision Time Protocol/IEEE-1588* for more information.

#### **cpuopts**

This command displays the current settings for the installed CPU Module outputs.

```
Query:                cpuopts
Meridian response:    CPU Option TIME CODE is installed.
Current Setting = IRIG-B122.
```

#### **cpuoptsconfig**

This command starts an interactive shell script that will allow the root user to change the settings of any installed CPU options. The user-selectable options are: 1PPS, AM Code, and the optional Programmable TTL Output.

```
Set:                  cpuoptsconfig
Meridian response:    Interactive shell script is started.
```

#### **cpusertime**

This command displays the current settings for the optional Serial Time Output. Settings for the three NMEA sentences are always shown but are only applicable if you have selected NMEA as the output format setting. More information about the various formats is in *Chapter 6 - Optional Rear-Panel Outputs*.



Query: **cpusertime**  
Meridian response: **Current Serial Time Output Baud Rate Setting = 9600**  
**Current Serial Time Output Format Setting = Sysplex**  
**Current Serial Time Output Parity Setting = Odd**  
**Current NMEA Sentence 1 Setting - ZDA**  
**Current NMEA Sentence 2 Setting - NONE**  
**Current NMEA Sentence 3 Setting - NONE**

### **cpusertimeconfig**

This command starts an interactive shell script that will allow the root user to change the settings of the optional Serial Time Output. The user-selectable outputs are the format (Sysplex, Truetime, EndRun, EndRunX, NENA0, NENA1, NENA8 and NMEA), the baud rate (4800, 9600, 19200, 57600) and the parity (ODD, EVEN, or NONE). The three NMEA sentences can also be changed but are applicable only if the Output Format is NMEA. More information about the various formats is in *Chapter 6 - Optional Rear-Panel Outputs*.

Set: **cpusertimeconfig**  
Meridian response: Interactive shell script is started.

### **csyshwaddr**

This command displays the ethernet hardware address, if the IP network is properly configured. Otherwise it returns nothing.

Query: **csyshwaddr**  
Meridian response: **00:0E:FE:00:00:33**

### **csysostype**

This command displays the installed oscillator type. It is one of TCXO, MS-OCXO, HS-OCXO, US-OCXO, Rb or HS-Rb. The standard oscillator is the TCXO.

Query: **csysostype**  
Meridian response: **Installed Oscillator is TCXO**

### **csyspasswd**

This command allows the root user to change the passwords of the two configured users on the system: *root* and *csysuser*. Arguments passed to **csyspasswd** on the command line are passed verbatim to the real **passwd** binary program. When **passwd** returns, the resulting modified */etc/shadow* file is copied to the non-volatile */boot/etc* directory.

To change root password:

Set: **csyspasswd**  
Meridian response: The passwd interactive utility starts.

To change csysuser password:

Set: **csyspasswd csysuser**  
Meridian response: The passwd interactive utility starts.

**cysrootsfs**

This command displays the currently booted root file system image. It can be either MeridianCDMA\_0 (factory image) or MeridianCDMA\_1 (field upgrade image). Refer to *Appendix B - Upgrading the Firmware* for detailed instructions on performing the upgrade procedure.

```
Query:                               cysrootsfs
Meridian response:                   BOOT_IMAGE=MeridianCDMA_1
```

**cysstat**

This command allows the user to query the status of the NTP subsystem. It retrieves information from the NTP distribution `ntpq` binary using the `peers` command to determine the current synchronization status of the NTP subsystem. It then retrieves the last line in the logfile `/var/log/praecis0.monitor` controlled by the NTP daemon reference clock driver that communicates with the CDMA Subsystem. This logfile is updated every 16 seconds under normal operation. It parses and formats the data contained therein and prints this fixed-length (generally, grossly unsynchronized states could cause the floating offset field to overflow momentarily) string having these fields:

```
LKSTAT TO CDMA, Offset = +S.ssssss, TFOM = ? @ YEAR DOY HH:MM:SS.ssssssss LS
```

Where:

- LKSTAT is the system peer status of the NTP daemon relative to the CDMA Subsystem, either LOCKED or NOTLKD. NOTLKD can imply several things: the system has just started, there is a fault in the CDMA Subsystem which has caused NTP to either be unable to obtain timing information from the CDMA Subsystem or to reject the timing information that it is obtaining from it.
- +S.ssssss is the offset in seconds between the NTP system clock and the CDMA Subsystem clock. Positive implies that the system clock is ahead of the CDMA Subsystem clock.
- TFOM = ? A detailed explanation of TFOM is in *Appendix A - Time Figure-of-Merit*. Briefly, TFOM indicates clock accuracy where:
- 6 time error is < 100 us
  - 7 time error is < 1 ms
  - 8 time error is < 10 ms
  - 9 time error is > 10 ms, unsynchronized state if never locked to CDMA.
- YEAR is the year of the UTC timestamp of most recent NTP polling request received by the CDMA Subsystem from the NTP reference clock driver.
- DOY is the day-of-year of the UTC timestamp of most recent NTP polling request received by the CDMA Subsystem from the NTP reference clock driver.
- HH:MM:SS.ssssssss is the hour, minute, second.subsecond UTC timestamp of the most recent NTP polling request received by by the CDMA Subsystem from the NTP daemon reference clock driver.
- LS is the current number of leap seconds difference between the UTC and GPS timescales (13 at the time of this writing).

Query: **csysstat**  
Meridian response:  
**LOCKED TO CDMA, Offset = +0.000024, TFOM = 4 @ 2001 092 06:03:10.904312858 13**

### **csystimemode**

This command displays the current time mode settings for the AM Code Output (time code) or optional Serial Time Output. Selections are UTC, GPS, Local-Auto and Local-Manual. The displayed local time offset from UTC is valid in either of the two local modes, but the Daylight Savings Time (DST) start/stop parameters are only valid in the local-manual mode. A positive local time offset implies a longitude east of the Greenwich meridian and that local time is ahead of UTC.

In the local-automatic mode, the local offset from UTC is determined from the CDMA base station transmissions. For more precise and deterministic behavior at the DST changeover times, you should configure your unit for local-manual operation and set up the local offset and the DST start and stop times using **csystimemodeconfig**.

Query: **csystimemode**  
Meridian response: **Time Mode = LOCAL\_MANUAL  
Local Time Offset from UTC = -16 (half hours)  
DST Start Month = Apr Sunday = 1st Hour = 02  
DST Stop Month = Oct Sunday = Last Hour = 02**

### **csystimemodeconfig**

This command starts an interactive shell script that will allow the user to configure the time mode of the AM Code Output (time code) or optional Serial Time Output. Options are GPS, UTC, Local-Auto and Local-Manual. *These settings have no effect on the operation of the underlying Linux operating system time. It ALWAYS operates in UTC.*

By default, the unit is configured to operate in UTC time mode. If you need to modify this setting, you must run this script as *root*. Settings made using this command are non-volatile.

Set: **csystimemodeconfig**  
Meridian response: Interactive shell script is started.

### **csysversion**

This command displays the firmware version and build date of the Linux Subsystem (root file system).

Query: **csysversion**  
Meridian response:  
**Meridian CDMA 6010-0042-000 v 1.00 Fri Aug 20 22:38:21 UTC 2004**

### **eraserootfs\_1**

This command erases the UPGRADE root file system FLASH partition in preparation for performing a Linux Subsystem firmware upgrade. See *Appendix B - Upgrading the Firmware* for more information.

Set: **eraserootfs\_1**  
Meridian response: Erase progress as percent is shown.

### **help**

This command displays a list of the Meridian commands (not Linux commands). To get help on a particular command you would type **help**, followed by the command.

Query: **help**  
Meridian response: Meridian commands are displayed.

Query: **help cdmastat**  
Meridian response: Information specific to the **cdmastat** command is displayed.

### **inetdconfig**

This command starts an interactive shell script that will allow the user to configure the list of protocol servers which are started by the **inetd** server daemon running in the Meridian. Three protocol servers may be configured: TIME, DAYTIME, and TELNET. By default, the unit is configured to start all of these protocol servers. If you need to disable start-up of some or all of these, e.g. for security reasons, you must run this script as **root** from either the RS-232 serial I/O port or from a **telnet** or **ssh** session.

This script modifies the */etc/inetd.conf* file, which is non-volatilely stored in the FLASH disk */boot/etc* directory. You must reboot the Meridian after running this script for the changes to take effect.

Set: **inetdconfig**  
Meridian response: Interactive shell script is started.

### **kplockstat**

This command prints the status, either locked or unlocked, of the front-panel keypad EDIT key. When the EDIT key is locked, it will prevent unauthorized tampering with the unit. All other keys are still enabled so you may continue to read the status and current settings of the Meridian. Refer to the **lockoutkp** and **unlockkp** commands.

Set: **kplockstat**  
Meridian response: **UNLOCKED**

### **lockoutkp**

This command locks out access to the front-panel keypad EDIT key. When the EDIT key is locked, it will prevent unauthorized tampering with the unit. All other keys are still enabled so you may continue to read the status and current settings of the Meridian. Refer to the **kplockstat** and **unlockkp** commands.

Set: **lockoutkp**  
Meridian response: Front-panel keypad EDIT key disabled.

**netconfig**

This command starts an interactive shell script that will allow the user to configure the IP network subsystem of the Meridian. By default, the unit is configured to configure itself using the Dynamic Host Configuration Protocol (DHCP). If you need to set up static IP configuration, you must run this script as *root* from the RS-232 serial I/O port during the installation process. Refer to **Chapter 2 - Using netconfig to Set Up Your IP** for details on the use of the command.

This script creates or modifies these files: */etc/HOSTNAME*, */etc/hosts*, */etc/networks*, */etc/resolv.conf* and */etc/rc.d/rc.inet1*. All of these are non-volatilely stored in the FLASH disk */boot/etc* directory. You must reboot the Meridian after running this script for the changes to take effect.

Set:	<b>netconfig</b>
Meridian response:	Interactive shell script is started.

**ntpconfig**

This command starts an interactive shell script that will allow the user to configure the NTP subsystem of the Meridian. By default, the unit is configured to authenticate its replies to clients using its default MD5 keys in the */etc/ntp.keys* file. If you need to create your own MD5 keys (recommended) or set up broadcast/multicast operation, you must run this script as *root*. Refer to **Chapter 5 - Setting Up the NTP Server** for details on the use of this command.

The two files that are modified are */etc/ntp.keys* and */etc/ntp.conf*. Both of these are non-volatilely stored in the FLASH disk */boot/etc* directory. You must reboot the Meridian after running this script for the changes to take effect.

Set:	<b>ntpconfig</b>
Meridian response:	Interactive shell script is started.

**oscctrlstat**

This command displays the current settings for the oscillator control parameters. These parameters are used to discipline the oscillator. The command formats the data and prints this fixed-length string having these fields:

```
Oscctrlstat = LKSTAT COAST ESTERR MEASERR TIMEDEV AGERATE TAU DAC TEMP
```

Where:

LKSTAT	is the CDMA Subsystem control status, either acquiring, tracking, locking or locked.
COAST	is the number of seconds in coast mode (unlocked).
ESTERR	is the estimated time error when in coast mode in seconds.
MEASERR	is the last measured time offset while locked in seconds.
TIMEDEV	is the time deviation (TDEV) of measurements in seconds.

- AGERATE is the regression computed oscillator ageing rate per day (several hour delay before the first measurements are displayed.).
- TAU is the oscillator control loop averaging time constant in seconds.
- DAC The oscillator control DAC value indicates the frequency control setting. The system automatically sets this value to remove frequency errors. Values may range from 0 to 1048575. Values close to the maximum/minimum will set the DAC fault flag that will appear in the fault status display. The Time/Status display will also indicate a fault condition.
- TEMP is the internal temperature in °C for OCXO oscillator only.

```

Query:                oscctrlstat
Meridian response:
Oscctrlstat = LKD  0 2.72e-09 -2.72e-09 1.23e-09 -0.00e+00  235.2  524332 -999.999
    
```

**pluginopts**

This command displays the current settings for any installed option boards. See *Chapter 6 - Optional Rear-Panel Outputs* for more information on the various option boards.

```

Query:                pluginopts
Meridian response:    Digital Buffer, 2001-0004-012-NC is installed.
                    Port A Current Setting = 10M PPS.
                    Port B Current Setting = 5M PPS.
                    Port C Current Setting = 10 PPS.
                    Port D Current Setting = 10 PPS.
    
```

**pluginoptsconfig**

This command starts an interactive shell script that will allow the root user to change the settings of any installed, user-selectable, option board outputs. The user-selectable outputs are all board-specific. For more information see *Chapter 6 - Optional Rear-Panel Outputs*.

```

Set:                  pluginoptsconfig
Meridian response:    Interactive shell script is started.
    
```

**ptpconfig and ptp2config (Optional)**

These commands are only available if the PTP/IEEE-1588 option has been installed. Refer to *Appendix K - Precision Time Protocol/IEEE-1588* for more information.

**ptpversionconfig (Optional)**

This command is only available if the PTP/IEEE-1588 option has been installed. Refer to *Appendix K - Precision Time Protocol/IEEE-1588* for more information.

**setcdmacdelay**

This command starts an interactive shell script that allows the user to change the clock calibration delay. This setting is used to advance or retard the clock in order to compensate for antenna cable length or other external hardware. Allowable range is +500000 to -500000 nanoseconds.

Set: **setcdmacdelay**  
Meridian response: Interactive shell script is started.

**setcdmachannelset**

This command sets the CDMA channelset to be used by the CDMA Subsystem. By factory default, the channelset is North American Cellular, unless the unit is configured for Japanese Cellular operation. In that case the hardware configuration limits operation to only the Japanese Cellular band, and this command will have no affect. The command requires one argument, which may be one of these three strings: NAC (North American Cellular), SKC (South Korean Cellular) , NAP (North American PCS), or IND (India Cellular).

Set: **setcdmachannelset NAP**  
Meridian response: **Channelset is North American PCS**

**setsigfltmask**

This command allows the user to enable or mask the Signal Loss Fault. Parameter for this command is either MASKED or ENABLED. Setting this command to MASKED will prevent a signal loss fault from creating an alarm condition. Some installations may need to mask this fault when operating the NTP server as a Stratum 2 server. The factory default setting is ENABLED.

Set: **sigfltmask MASKED**  
Meridian response: **Signal Loss Fault Mask set to MASKED**

**settfomfltmask**

This command allows the user to change the TFOM Fault Level. This is the threshold at which a signal loss fault will be asserted. See *Appendix A - Time Figure of Merit* for more information. By changing the TFOM Fault Level you control the point at which the time error will produce a signal loss fault, which then creates an alarm condition. The factory default setting is 9, which is the maximum TFOM value.

Set: **settfomfltlvl 6**  
Meridian response: **TFOM Fault Level set to 6**

**sigfltmask**

This command displays the current setting for the Signal Loss Fault Mask.

Query: **sigfltmask**  
Meridian response: **Signal Loss Fault is ENABLED**

**tfomfltlvl**

This command displays the current setting for the TFOM Fault Level.

```
Query:                tfomfltlvl
Meridian response:    9
```

**unlockkp**

This command unlocks access to the front-panel keypad EDIT key. When the EDIT key is locked, it will prevent unauthorized tampering with the unit. All other keys are still enabled so you may continue to read the status and current settings of the Meridian. Refer to the **kplockstat** and **lockoutkp** commands.

```
Set:                  unlockkp
Meridian response:    Front-panel keypad EDIT key enabled.
```

**updaterootflag**

This command allows the user to update the configuration of the Linux bootloader after a new root file system image has been uploaded to the UPGRADE root file system partition, */dev/rootfs\_1* of the Meridian FLASH disk. It may also be used to reset the default back to the FACTORY root file system partition. Refer to *Appendix B - Upgrading the Firmware* for detailed instructions for performing the upgrade procedure. One argument is accepted, whose value is either 0 or 1, causing a flag to be set that will indicate to the bootloader which root file system image should be loaded by default. If an argument value of 2 is given, then the currently configured default root file system is shown.

```
Set:                  updaterootflag 1
Meridian response:    UPGRADE is the default root file system.
```

```
Query:                updaterootflag 2
Meridian response:    UPGRADE is the default root file system.
```

**upgradcdma**

This script allows the user to upgrade the CDMA Subsystem firmware. It requires one argument: the path to the binary file to be uploaded to the CDMA Subsystem. It issues the commands over the serial port to the CDMA Subsystem that are needed to start the X-modem file transfer, and then displays the responses from the CDMA Subsystem to the console. When the X-modem 'C' character appears, indicating that the CDMA Subsystem is ready to receive the file, you must hit the <ENTER> key, and the transfer will begin. After about one minute, it should complete, at which point you should see the CDMA Subsystem boot messages appear on the console. From these, you will be able to verify that the firmware was successfully upgraded.

In the example console output below, lines which begin with "---" are generated by the **upgrad-ecdma** script. All other lines are from the CDMA Subsystem, with the exception of the shell message indicating that the process **cat < /dev/arm\_user** has been terminated, which is normal. In this example, the 'C' character was received three times before the user hit the <ENTER> key to begin the transfer. The last three lines are the boot messages that are sent by the CDMA Subsystem as it



comes up. The firmware version should match that of the binary file that was uploaded. See *Performing the CDMA Upgrade* in *Appendix B - Upgrading the Firmware* for more information.

```
Set:                               upgradecdma /tmp/6010-0020-000.bin
Meridian response:
---When you see the `C` character, hit <enter> to begin the upload.

Waiting for download using XMODEM 128 or XMODEM 1K (both with CRC).
Control X will abort download.
CCC
---Starting file upload, should take about 90 seconds...

/sbin/upgradecdma: line 26: 27618 Terminated          cat </dev/arm_user

---You should see the CDMA subsystem startup message now.  If not, you
---may need to check your binary file and re-perform the procedure.

Tempus Bootloader 6010-0050-000 v 1.00 - May 28 2004 17:31:05
FW 6010-0020-000 v 1.00 - Aug 18 2004 10:47:41
FPGA 6020-0005-000 v 0202
```

**upgradkernel**

This script allows the user to change the Linux kernel firmware. It requires one argument: the path to the file to be uploaded to the Meridian. Changing the Linux kernel firmware will enable IPv6 operation and should only be done if you have a requirement for IPv6. See *Appendix I - IPv6 Information* and *Performing the Linux Kernel Upgrade* in *Appendix B - Upgrading the Firmware* for more information.

```
Set                               upgradkernel /tmp/newkernelimage
Meridian response:                Interactive shell script is started.
```

**RS-232 Serial I/O Port  
Signal Definitions**

The RS-232 DB9M connector on the rear panel of the Meridian is wired as shown below. In order to connect the Meridian to another computer, a null-modem adapter must be used. The serial cable provided with the shipment is wired as a null-modem adapter and can be used to connect the Meridian to your computer.

Meridian DB9M Pin	Signal Name
1	Not Connected
2	Receive Data (RX)
3	Transmit Data (TX)
4	Data Terminal Ready (DTR)
5	Ground
6	Data Set Ready (DSR)
7	Request To Send (RTS)
8	Clear To Send (RTS)
9	Not Connected



# Chapter Five

## Setting Up the NTP Server

*This chapter will guide you through the configuration of the Network Time Protocol (NTP) server. When operating your Meridian with its standard network interface, basic familiarity with TCP/IP networking protocols like ping, telnet and ftp is required. Though some familiarity with Linux or other Unix-like operating systems would be helpful, it is not essential.*

*Instructions for setting up the NTP Clients are given in **Appendix E - Setting Up NTP Clients on Unix-Like Platforms** and in **Appendix F - Setting Up NTP Clients on Windows NT 4.0/2000/XP**.*

### Configuring the Network Time Protocol

This chapter assumes that the network port has been configured and tested as per the instructions in **Chapter 2 - Basic Installation**. Once this has been done, you may configure the operation of the NTP server. By default, the Meridian is configured to respond to NTP requests from clients that may or may not be using MD5 authentication. If the clients are using MD5 authentication, they must be configured properly with the same MD5 authentication keys as the Meridian. If you need to modify the factory default Meridian MD5 keys (recommended) or set up broadcast/multicast operation, then you will need to reconfigure the NTP subsystem. You may perform the configuration from either a **telnet** or **ssh** session, the front-panel keypad, or the local RS-232 console.

#### NOTE

If you would like to configure your server for multicast operation, configure it as you would for broadcast operation, with the exception that you must enter this specific NTP multicast address: 224.0.1.1, when you are prompted to enter the broadcast address.

#### Configuring NTP Using the Front-Panel Keypad

To configure NTP using the front-panel keypad go to the Main Menu display. Press the RIGHT arrow key until the “NTP” selection is highlighted. Press ENTER again. Press the RIGHT arrow key to highlight “Setup” and press ENTER. From this display you can configure broadcast/multicast mode. You can also select previously configured MD5 authentication keys from this display. However, to configure new keys you will need to run **ntpconfig**.

#### Configuring NTP Using the Network Interface or Serial Port

The following is a transcript of the question and answer configuration utility provided by **ntpconfig**. The user entered parameters are underlined:

```
Meridian CDMA(root@gsys:~)-> ntpconfig
```

---

## CHAPTER FIVE

```
*****
*****Network Time Protocol Configuration*****
*****
*
* This script will allow you to configure the ntp.conf and ntp.keys files
* that control Meridian NTP daemon operation.
*
* You will be able to create new MD5 authentication keys which are stored
* in the ntp.keys file.
*
* You will be able to update the authentication related commands in the
* ntp.conf file.
*
* You will be able to configure the "broadcast" mode of operation, with
* or without authentication. If you supply the multicast address instead
* of your network broadcast address, then you will be able to configure
* the time-to-live of the multicast packets.
*
* The changes you make now will not take effect until you re-boot the
* Meridian CDMA. If you make a mistake, just re-run ntpconfig prior to
* re-booting.
*
* You will now be prompted for the necessary set up parameters.
*
*****
*****

--MD5 Keyfile Configuration

Would you like to create a new ntp.keys file? ([y]es, [n]o) y

You will be prompted for a key number (1 - 65534), then the actual key.
When you have entered all of the keys that you need, enter zero at the next
prompt for a key number.

MD5 keys may contain from 1 to 31 ASCII characters. They may not contain
SPACE, TAB, LF, NULL, or # characters!

Enter a key number (1-65534) or 0 to quit: 1

Enter the key (1-31 ASCII characters): EndRun Technologies LLC

Writing key number: 1 and Key: EndRun_Technologies_LLC to ntp.keys

Enter a key number (1-65534) or 0 to quit: 2

Enter the key (1-31 ASCII characters): Tempus CDMA

Writing key number: 2 and Key: Tempus_CDMA to ntp.keys
Enter a key number (1-65534) or 0 to quit: 0

--NTP Authentication Configuration
Do you want authentication enabled using some or all of the keys in
the ntp.keys file? ([y]es, [n]o) y

You will be prompted for key numbers (1 - 65534), that you want NTP to
"trust". The key numbers you enter must exist in your ntp.keys file. If you
do not want to use some of the keys in your ntp.keys file, do not enter them
here. NTP will treat those keys as "untrusted".

Clients that use any of the "trusted" keys in their NTP polling packets will
receive authenticated replies from the Meridian CDMA. When you have entered
all of the "trusted keys" that you need, enter zero at the next prompt for a
key number.
```

---

## SETTING UP THE NTP SERVER

Enter a trusted key number (1-65534) or 0 to quit: 1

Enter a trusted key number (1-65534) or 0 to quit: 2

Enter a trusted key number (1-65534) or 0 to quit: 0

---NTP Broadcast/Multicast Configuration

Would you like to enable broadcast/multicast server operation? ([y]es, [n]o) y

Set the network broadcast/multicast address for the Meridian CDMA to use. For broadcast mode, this address is the all 1's address on the sub-net.

Example: 111.112.113.255

For multicast operation, it is this specific address: 224.0.1.1

Enter IP address for NTP broadcast/multicast operation (aaa.bbb.ccc.ddd): 224.0.1.1

You have selected multicast operation. Enter the number of hops that are needed for the multicast packets on your network (positive integer): 1

It is highly recommended that authentication be used if you are using NTP in broadcast/multicast mode. Otherwise clients may easily be "spoofed" by a fake NTP server. You can specify an MD5 key number that the Meridian CDMA will use in its broadcast/multicast packets. The clients on your network must be configured to use the same key.

Would you like to specify an MD5 key number to use with broadcast mode? ([y]es, [n]o) y

Enter the MD5 key number to use (1-65534): 2

```
*****
*****
*
*   The Meridian CDMA Network Time Protocol configuration has been updated.   *
*
*           Please re-boot now for the changes to take effect.           *
*
*****
*****
```

**Configuring the Meridian as a Stratum 2 Server**

Operating the Meridian as a Stratum 1 Server is the recommended mode. You may operate the unit as a Stratum 2 server but since there are innumerable ways to configure your network with Stratum 2 servers, specific instructions for how to do that are beyond the scope of this manual. General instructions are:

**Edit NTP.CONF**

You must edit the `ntp.conf` file in order to point your Stratum 2 server at a Stratum 1 server. Edit `/etc/ntp.conf` and add your server line(s). (See *Using Edit* below.) Here is an example:

```
server 192.168.1.1
```

**IMPORTANT!!** Do not remove the server lines for the refclock. Even if your Time Server is not connected to an antenna - the refclock server lines must remain.

Now save the edited file and copy it to the non-volatile flash partition with this command:

```
cp -p /etc/ntp.conf /boot/etc
```

**Mask Alarm**

In Stratum 1 operation an alarm will be indicated when there is a loss of signal. For Stratum 2 operation you may not want to see this alarm. You can mask it (prevent it from showing) by using the console port (serial/network) command `setsigfltmask`. On the front-panel keypad/display go to the Receiver sub-menu. Look for `SigFltMask` and set it appropriately.

**Using Edit**

A very compact editor is available on the system for editing files: `edit`. If you start `edit` without giving it a file name to open, it will display its help screen, showing all supported keystrokes.

# Chapter Six

## Optional Rear-Panel Outputs

Your Meridian CDMA Frequency Reference supports several output options via the CPU module and up to five plug-in option cards. Status and user settings for the various output signals can be easily viewed and modified via the front-panel keypad and display, the standard network port, or the RS-232 serial port.

This chapter describes the various options available in the Meridian product line. Refer to Appendix L for details on signal specifications, connector types, pinouts, etc.

### CPU Module Options

Standard rear-panel configuration for the CPU module is the Antenna input, the AM Code output, the 1 PPS output, the RS-232 connector and the ethernet connector. Information for the standard outputs, including getting status and control capability via the user interface is described in the main text of this manual. Refer to **Chapter 2 - Basic Installation** for a physical description of the Meridian rear-panel and its various outputs. Refer to **Chapter 3 - Front-Panel Keypad and Display** for details on the Option I/O Menu and refer to **Chapter 4 - Control and Status Commands** for details on the `cpuopts` and `cpuoptsconfig` commands.

In addition to the standard connectors, the CPU module can be configured with optional outputs. These optional outputs include a Programmable TTL Output, a Synthesizer Output, an Alarm Output, and a second RS-232 serial port with a Serial Time Output.

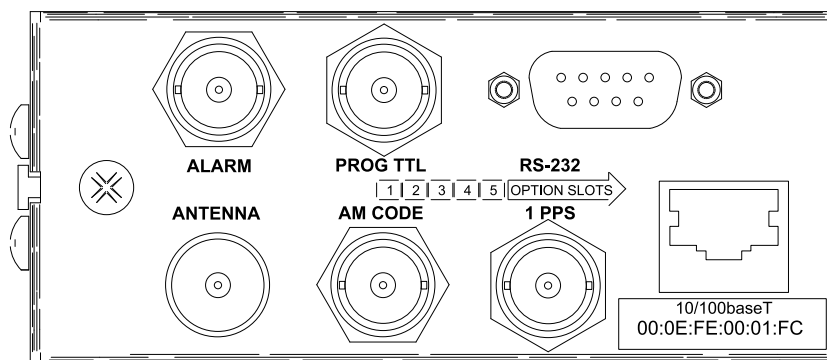

#### Programmable TTL Output

The Programmable TTL Output option provides user-selectable, on-time pulse rates from 1 PPS to 10 MPPS, or a digital time code. Other selections are 1PPM (pulse per minute), 1PP2S (pulse per 2 seconds/even second), 1PPS+OT (rising edge on time), 1PPS-OT (falling edge on time) and SYNTH (see DDS option below). The output signal can be programmed for any of the various selections via the front-panel display by navigating to Main Menu > Option I/O > CPU-I/O > ProgTTL. Alternatively, you can change the output signal via the network or serial port by using console command

**cpuoptsconfig.** Refer to Chapter 3 for details on the Option I/O Menu and refer to Chapter 4 for details on the **cpuopts** and **cpuoptsconfig** commands. For signal definition see *Appendix L - Specifications*.

#### **Direct Digital Synthesizer (DDS)**

The Programmable TTL Output option may be upgraded with the addition of the Direct Digital Synthesizer selection. This option provides user-selectable pulse rates from 1 PPS to 10 MPPS, programmable in 1 PPS steps, including 1.544 MPPS or 2.048 MPPS. The selected pulse rate is phase locked to the system oscillator. However, the DDS output is not aligned with system time.

If your Meridian has this option available then it will show up as “SYNTH” in the list of available selections for the Programmable TTL Output. The actual synthesizer frequency is set via the front-panel keypad by navigating to Main Menu > Option I/O > CPU-I/O > Synthesizer. Alternatively, you can change the synthesizer rate via the network or serial port by using console command **cpuoptsconfig** (see Chapter 4). For signal definition see *Appendix L - Specifications*.

#### **Fixed Pulse Rate Output (10 MPPS, etc.)**

The Fixed Pulse Rate Output option provides an optional customer-specified fixed rate output ranging from 1 PPS to 10 MPPS, or a digital time code. The rear-panel BNC will be labeled for the appropriate rate such as “10 MPPS” or “100 PPS”, etc. This signal is specified by the customer when the order is placed, preset at the factory, and cannot be changed. There is no user interface status or control. For signal definition see *Appendix L - Specifications*.

#### **1 PPS (RS-422) Output**

This option is provided on a second RS-232 serial port which replaces the two upper BNCs on the CPU Module. The pulse width is normally 1 millisecond wide when shipped from the factory but can be changed via the front-panel keypad or via the console command **cpuoptsconfig**. See signal definition in *Appendix L - Specifications* for the 1PPS RS-422 output.

#### **Serial Time Output**

This option is provided on a second RS-232 (or RS-422) serial port labeled “Serial Time”. It replaces the two upper BNCs on the CPU Module. It is an output that provides a once-per-second sequence of ASCII characters indicating the current time. The “on-time” character is transmitted during the first millisecond of each second for 9600 baud or higher. (Specifically, the leading edge of the start bit of the “on-time” character is transmitted within 100 microseconds of the beginning of each second.) The output starts automatically on power-up. See *Appendix L - Specifications* for pinout.

To configure this output use either the Serial Time Output setup menu (see *Chapter 3 - Front-Panel Keypad and Display*) or the **cpusertime** and **cpusertimeconfig** commands (see *Chapter 4 - Control and Status Commands*).

There are several different formats for this string. The format, baud rate and parity can all be changed via the front-panel keypad or via the console command **cpusertimeconfig**. Baud rate selections are 57600, 19200, 9600, and 4800. Parity selections are odd, even, and none. Format selections are Sysplex, Truetime, EndRun, EndRunX, NENA and NMEA.

#### **Sysplex Format**

“Sysplex” means SYStem comPLEX and is a term used to describe computing on clusters of computers. The Sysplex option is designed to provide time synchronization for an IBM Sysplex Timer. It can also be used for precise time synchronization by any computers that do not use NTP and have an



---

## OPTIONAL REAR-PANEL OUTPUTS

available serial port connection. The time contained in this string format is always UTC time. The following string is sent once each second:

<SOH>DDD:HH:MM:SSQ<CR><LF>

<SOH> is the ASCII Start-of-Header character (0x01)  
DDD is the day-of-year  
: is the colon character (0x3A)  
HH is the hour of the day  
MM is the minute of the hour  
SS is the second of the minute  
Q is the time quality indicator and may be either:  
<space> ASCII space character (0x20) which indicates locked  
? ASCII question mark (0x3F) which indicates  
the unsynchronized condition  
<CR> is the ASCII carriage return character (0x0D) and is the on-time  
character, transmitted during the first millisecond of each second.  
<LF> is the ASCII line feed character (0x0A)

### Truetime Format

The format of the Truetime string is identical to the Sysplex format. The only difference between the two is that the Sysplex format always uses UTC time. The time contained in the Truetime format depends on the time mode of the Meridian. For example, if you want an output with this string format that uses Local Time, then select the Truetime format.

### EndRun Format

The time contained in this string depends on the time mode of the Meridian. For example, if you want the time in this string to be UTC, then set the time mode of the Meridian to UTC. (You can do this by using the front-panel keypad/display or the console port (see **csystemmodeconfig** in *Chapter 4 - Control and Status Commands*). The following string is sent once each second:

T YYYY DDD HH:MM:SS zZZ m<CR><LF>

T is the Time Figure of Merit (TFOM) character described in *Appendix A - TFOM*.  
This is the on-time character, transmitted during the first millisecond of each second.  
YYYY is the year  
DDD is the day-of-year  
: is the colon character (0x3A)  
HH is the hour of the day  
MM is the minute of the hour  
SS is the second of the minute  
z is the sign of the offset to UTC, + implies time is ahead of UTC.  
ZZ is the magnitude of the offset to UTC in units of half-hours.  
Non-zero only when the Timemode is Local.  
m is the Timemode character and is one of:  
G = CDMA  
L = Local  
U = UTC  
<CR> is the ASCII carriage return character (0x0D)  
<LF> is the ASCII line feed character (0x0A)

**EndRunX (Extended) Format**

The EndRunX format is identical to the EndRun format with the addition of two fields - the current leap second settings and the future leap second settings. The following string is sent once each second:

T YYYY DDD HH:MM:SS zZZ m CC FF<CR><LF>

- T is the Time Figure of Merit (TFOM) character described in *Appendix A - TFOM*. This is the on-time character, transmitted during the first millisecond of each second.
- YYYY is the year
- DDD is the day-of-year
- :
- HH is the hour of the day
- MM is the minute of the hour
- SS is the second of the minute
- z is the sign of the offset to UTC, + implies time is ahead of UTC.
- ZZ is the magnitude of the offset to UTC in units of half-hours.  
Non-zero only when the Timemode is Local.
- m is the Timemode character and is one of:  
G = CDMA  
L = Local  
U = UTC
- CC is the current leap seconds value.
- FF is the future leap seconds which will show a leap second pending 24 hours in advance.
- <CR> is the ASCII carriage return character (0x0D)
- <LF> is the ASCII line feed character (0x0A)

**NENA Format**

NENA is the National Emergency Number Association. This organization has adopted several ASCII time code formats for use in PSAPs (Public Safety Answering Points) and they are specified in the NENA PSAP Master Clock Standard, Issue 4. These ASCII time code formats are NENA Format 0 (NENA0), NENA Format 1 (NENA1), and NENA Format 8 (NENA8):

**NENA0**

<CR><LF>Q<sup>^</sup>DDD<sup>^</sup>HH:MM:SS<sup>^</sup>dTZ=XX<CR><LF>

- Q is the time quality indicator and may be either:  
<space> ASCII space character (0x20) which indicates locked.  
? ASCII question mark (0x3F) which indicates the unsynchronized condition.  
This is the “on-time” character.
- <sup>^</sup> is the space character (0x20).
- DDD is the day-of-year (001-366)
- :
- HH is the hour-of-the-day (00-23)
- MM is the minute-of-the-hour (00-59)
- SS is the second-of-the-minute (00-60)
- d is the DST indicator (S,I,D,O).
- TZ=XX is the time zone where XX is 00 through 23

---

## OPTIONAL REAR-PANEL OUTPUTS

<CR> is the ASCII carriage return character (0x0D).  
The first <CR> is the on-time character.  
<LF> is the ASCII line feed character (0x0A).

### NENA1

<CR><LF>Q^WWW^DDMMYY^HH:MM:SS<CR><LF>

Q is the time quality indicator and may be either:  
<space> ASCII space character (0x20) which indicates locked.  
? ASCII question mark (0x3F) which indicates the unsynchronized condition.  
This is the “on-time” character.  
^ is the space character (0x20).  
WWW is the day-of-week (MON, TUE, WED, THU, FRI, SAT)  
DD is the day-of-month (1-31)  
MMM is the month (JAN, FEB, MAR, APR, MAY, JUN, JUL, AUG, SEP, OCT, NOV, DEC)  
YY is the two-digit year  
: is the colon character (0x3A)  
HH is the hour-of-the-day (00-23)  
MM is the minute-of-the-hour (00-59)  
SS is the second-of-the-minute (00-60)  
<CR> is the ASCII carriage return character (0x0D).  
The first <CR> is the on-time character.  
<LF> is the ASCII line feed character (0x0A)

### NENA8

<CR><LF>Q^YYYY^DDD^HH:MM:SS^D+ZZ<CR><LF>

Q is the time quality indicator and may be either:  
<space> ASCII space character (0x20) which indicates locked.  
? ASCII question mark (0x3F) which indicates the unsynchronized condition.  
This is the “on-time” character.  
^ is the space character (0x20).  
YYYY is the four-digit year  
DDD is the day-of-year (001-366)  
: is the colon character (0x3A)  
HH is the hour-of-the-day (00-23)  
MM is the minute-of-the-hour (00-59)  
SS is the second-of-the-minute (00-60)  
d is the DST indicator (S,I,D,O).  
+ZZ + or - time zone offset relative to UTC (00-12)  
<CR> is the ASCII carriage return character (0x0D).  
The first <CR> is the on-time character.  
<LF> is the ASCII line feed character (0x0A).

### NMEA Format

The National Marine Electronics Association (NMEA) has developed a specification that defines the interface between various pieces of marine electronic equipment. This standard defines “sentences” that contain GPS position, navigation, time, and other information. Sentences that have been added to the Meridian product line are GGA, GLL, GSA, RMC, VTG and ZDA. However, position and

navigation information is not available in a CDMA-Synchronized product so the only sentence that has been fully implemented is ZDA (time and date information).

**ZDA (Time and Date)**

The ZDA sentence identifies the time associated with the current 1PPS pulse. Each sentence is transmitted within 500 milliseconds after the 1PPS pulse is output and tells the time of the pulse that just occurred. If the Meridian is unsynchronized then this sentence will be composed of null fields. Examples are below:

```
$GPZDA,,,,,*48<CR><LF>
$GPZDA,175658.00,20,05,2008,07,00*69<CR><LF>
```

Msg ID	\$GPZDA	“\$” is the on-time character.
Field 1	175658.00	UTC time at 1PPS (hhmmss.ss)
Field 2	20	Day (01 to 31)
Field 3	05	Month (01 to 12)
Field 4	2008	Year (1980 to 2079)
Field 5	07	Local zone hour, offset from UTC (- for east longitude)
Field 6	00	Local zone minutes, offset from UTC
Checksum	*69	
Msg End	<CR><LF>	

**Alarm Output**

The Alarm Output option provides an open-collector output that indicates when the CDMA receiver has lost lock, or when serious hardware faults are detected. For a detailed description of the faults see the *Faults* section in *Chapter 3 - Front-Panel Keypad and Display*. There is no user interface control for this option.

Care should be taken not to directly connect this open-collector output to a voltage source. A series current-limiting resistor of at least 1K ohms in value should be used. The pull-up voltage must not exceed 40V. For signal definition see *Appendix L - Specifications*.

**Plug-In Module Options**

Your Meridian is supplied with five option slots that can be configured with a variety of plug-in modules. Most of these modules can be added to the Meridian as “plug-and-play” options without hardware or software modification. At power-up, automatic recognition software detects the identity of any plug-in module installed and launches the corresponding software routines necessary to control and monitor the operation of each module. Standard plug-in modules are described below:

**Programmable Digital Buffer Module**

The Programmable Digital Buffer Module is a “plug-and-play” option that adds four independently programmable TTL outputs to your Meridian. These buffered outputs can provide on-time pulse rates from 1 PPS to 10 MPPS, or a digital time code output. Other selections are 1PPM (pulse per minute), 1PP2S (pulse per 2 seconds/even second), 1PPS+OT (rising edge on time), 1PPS-OT (falling edge on time) and SYNTH (see DDS option below). Each output can be individually programmed for any

---

## OPTIONAL REAR-PANEL OUTPUTS

of the various selections via the front-panel display by navigating to Main Menu > Option I/O > Opt-Cardx (see Chapter 3). To program the outputs via the network or serial port use console command **pluginoptconfig** (see Chapter 4). For signal definition see *Appendix L - Specifications*. The rear panel outputs are identified as PROG TTL A through D as shown below:

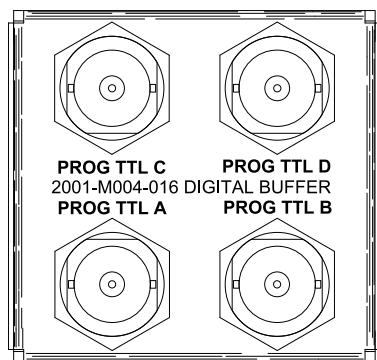

### Digital Time Code Formats

If you have selected time code as the output on the Digital Buffer Module then its format will be the same format as that on the standard CPU Module AM Code connector. This format can be changed via the front-panel display by navigating to Main Menu > Option I/O > CPU I/O > Code-Out (see Chapter 3). Alternatively, you can change the time code format via the network or serial port by using console command **cpuoptconfig** (see Chapter 4).

### Direct Digital Synthesizer (DDS)

An additional upgrade to the Programmable Digital Buffer Module provides access to the DDS that is resident on the Meridian CPU module. Programmable synthesized pulse rates from 1 PPS to 10 MPPS in 1 PPS steps are available, including 1.544 MPPS or 2.048 MPPS. The pulse rate is phase locked to the system oscillator. However, the DDS output is not aligned with system time.

If your Meridian has this option available then it will show up as “SYNTH” in the list of available selections for the Programmable Digital Buffer outputs. The actual synthesizer frequency that is resident on the Meridian CPU module is set via the front-panel keypad by navigating to Main Menu > Option I/O > CPU I/O > Synthesizer. Alternatively, you can change the synthesizer rate via the network or serial port by using console command **cpuoptconfig** (see Chapter 4).

### Digital Buffer Module

The Digital Buffer Module is a “plug-and-play” option that adds four buffered outputs to your Meridian TimeBase. Signal levels are either TTL (BNC connectors) or RS-232 (DB9M connector). The type of output is set up at the factory based on customer requirements and cannot be changed. Available outputs are on-time pulse rates from 1 PPS to 10 MPPS, 1PPM, 1PP2S, a synthesized rate, or a digital time code. All outputs are all aligned to system time except the synthesized rate (see DDS above). (Note that for the RS-232 level outputs, rates above 1 MPPS are impractical due to the 30 V/us RS-232 slew rate limit.)

If your Digital Buffer Module is set up for time code or synthesized rates then you can change the time code or rate via the front-panel keypad/display by navigating to Main Menu > Option I/O > CPU-I/O. You can also use command **cpuoptconfig**. The module configuration can be viewed by navigating to Main Menu > Option I/O > OptCardx (where x = 1-5) or by using console command

**pluginopts** (see Chapter 4). For signal definition and DB9M connector pinout see *Appendix L - Specifications*.

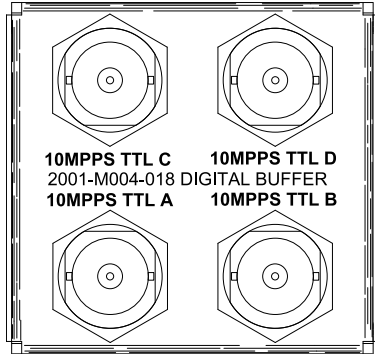

**Analog Time Code Buffer Module**

The Analog Time Code Buffer Module is a “plug-and-play” option that adds four additional time code outputs to your Meridian. These buffered outputs can provide synchronization of equipment such as synchronized generators, digital fault recorders, SCADA systems, and time displays, and are suitable for recording onto magnetic tape or for transmission over another medium such as coaxial cable. Available time code formats are: IRIG-B120 (IEEE-1344), IRIG-B122, IRIG-B123, NASA-36, or 2137. All four output connectors use the same code format. The format is identical to that of the CPU Module AM Code output which is set via the front-panel display by navigating to Main Menu > Option I/O > CPU-I/O > Code-Out. Alternatively, you can change the time code format via the network or serial port by using console command **cpuoptsconfig** (see Chapter 4). For signal definition see *Appendix L - Specifications*. The rear panel outputs are identified as OUTPUT A through D as shown below:

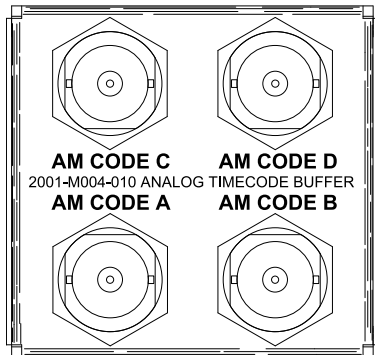

**Sine Wave Module**

The Sine Wave Module is an option that adds four frequency outputs to your Meridian. This module is intended for those wanting sine wave outputs without the need for the high-performance low-phase-noise.

Up to five of these modules can be installed. The first one needs to be installed and configured at the factory. Additional modules can be installed in the field as “plug-and-play” options. Available

## OPTIONAL REAR-PANEL OUTPUTS

frequencies are 1 MHz, 5 MHz and 10 MHz. The rear-panel outputs are labeled with their configured frequency. These frequencies are not changeable but can be viewed via the front-panel display by navigating to Main Menu > Option I/O > OptCardx (where x = 1-5). You can also view the Sine Wave Output configuration via the network or serial ports by using console command **pluginopts** (see Chapter 4). For signal definition see *Appendix L - Specifications*.

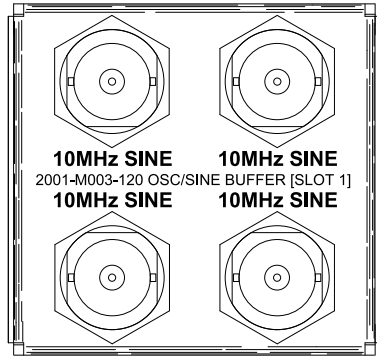

### Low Phase Noise Module

The Meridian can be configured with several high-performance, disciplined, 10-MHz oscillators. The low phase noise outputs work in conjunction with these oscillators to provide individually buffered, spectrally pure, sinewave outputs. The levels of the contributors to spectral impurity have been carefully controlled by the selection of the optional oscillators that are offered, and by the design of the option module and its integration into the Meridian chassis. In addition, very good channel-to-channel isolation has been achieved.

The Low-Phase-Noise Module with resident oscillator resides in Slot 1 (next to the CPU Module) and is not field-upgradeable. However, additional Low Phase Noise Modules (without an oscillator) can be installed in the field as plug-and-play options.

The rear-panel outputs are labeled with their configured frequency. These frequencies are not changeable but can be viewed via the front-panel display by navigating to Main Menu > Option I/O > OptCardx (where x = 1-5). You can also view the Low Phase Noise Module configuration via the network or serial ports by using console command **pluginopts** (see Chapter 4). For signal definition see *Appendix L - Specifications*.

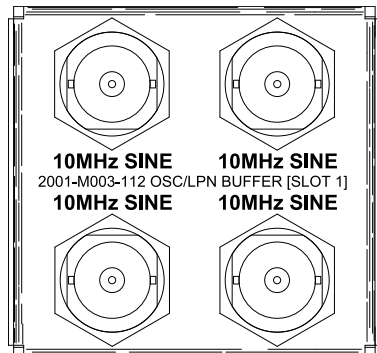

**Telecom Clock Module**

The Telecom Clock Module is a “plug-and-play” option that adds two or three outputs to your Meridian. Two outputs are available for any combination of T1, J1, E1 and Composite Clock. An alarm relay output is also available as an additional option. When the Meridian is configured with any of the available oscillator upgrades, it can operate as a Primary Reference Clock, providing high-stability Building Integrated Timing Supply (BITS) clock signals directly to digital equipment. For signal definition see *Appendix L - Specifications*.

**SAFETY WARNING**

This option does not incorporate over-voltage protection suitable for connection to the public telecommunications network. Do not connect to any wiring that leaves the building.

The rear-panel outputs are labeled with their configuration (E1, T1, J1, 64kCC, Alarm). Examples are below. This configuration cannot be changed but can be viewed via the front-panel display by navigating to Main Menu > Option I/O > OptCardx (where x = 1-5). You can also view the Telecom Clock Mutput configuration via the network or serial ports by using console command **pluginopts**,

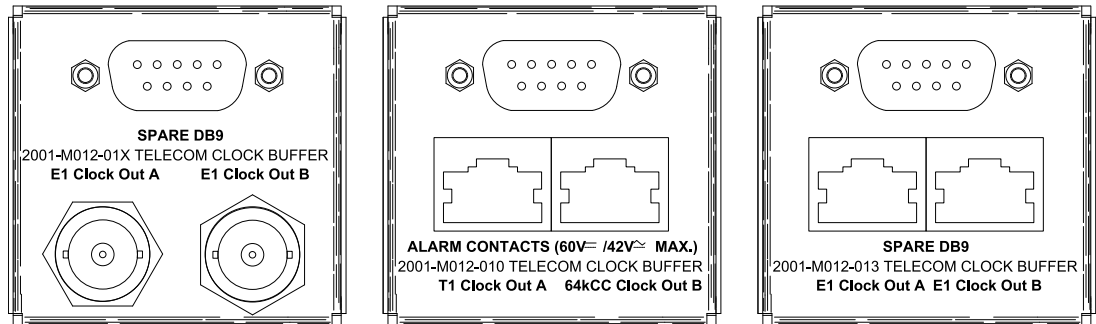

**User Settings**

There are user settings associated with the T1, J1, E1 and Composite Clock outputs. There are no user settings for the optional Alarm Output. User settings are:

- T1/J1: Framing Mode, Alarm Mode, Line Build-Out
- E1: Framing Mode, Alarm Mode
- Composite Clock: Line Code, Alarm Mode

You can view or change the user settings for each output by using the front-panel keypad/display (see *Chapter 3 - Front-Panel Kaypad and Display*) or by using the console commands **pluginopts** and **pluginoptsconfig** (see *Chapter 4 - Control and Status Commands*). Available selections for each user setting are:

- T1 Framing Mode: Unframed, SF (D4) and ESF (CRC6)
- T1 Alarm Mode: N/A\*, None, AIS, SSM
- T1 Line Build-Out: 1-133 feet, 133-266 feet, 266-399 feet, 399-533 feet, 533-655 feet
- J1 Framing Mode: SF(D4), ESF(CRC6)
- J1 Alarm Mode: None, AIS
- J1 Line Build-Out: 0-655 feet
- E1 Framing Mode: Unframed, FAS Double-Frame, CRC4 Multi-Frame



## OPTIONAL REAR-PANEL OUTPUTS

E1 Alarm Mode: N/A\*, None, AIS, SSM  
 Comp Clock Line Code: AMI, AMI with 8kHz BPV, AMI with 8kHz BPV+400Hz non-BPV  
 Comp Clock Alarm Mode: N/A\*, None, AIS  
 \*Alarm Mode not applicable when unframed (all ones).

### T1 USER SETTINGS VS CLOCK STATUS & ASSOCIATED SIGNAL CONDITIONS

USER SETTINGS	CLOCK STATUS	OUTPUT SIGNAL		
FRAMING/ALARM	ALARM STATE	FRAMING	SSM STATE	SSM Message
UNFRAMED ALARM: N/A	NONE	All 1's	N/A	N/A
	MAJOR (BLUE)	All 1's	N/A	N/A
	CRITICAL	All 0's	N/A	N/A
SF(D4) ALARM: NONE	NONE	SF(D4)	N/A	N/A
	MAJOR (BLUE)	SF(D4)	N/A	N/A
	CRITICAL	All 0's	N/A	N/A
SF(D4) ALARM: AIS	NONE	SF(D4)	N/A	N/A
	MAJOR (BLUE)	AIS(All 1's)	N/A	N/A
	CRITICAL	All 0's	N/A	N/A
ESF ALARM: NONE	NONE	ESF	G.811 Synchronization	11111111 00100000
	MAJOR (BLUE)	ESF	G.811 Synchronization	11111111 00100000
	CRITICAL	All 0's	N/A	N/A
ESF ALARM: AIS	NONE	ESF	G.811 Synchronization	11111111 00100000
	MAJOR (BLUE)	AIS(All 1's)	N/A	N/A
	CRITICAL	All 0's	N/A	N/A
ESF ALARM: SSM	NONE	ESF	G.811 Synchronization	11111111 00100000
	MAJOR (BLUE)	ESF	Do Not Use For Synchronization	11111111 00001100
	CRITICAL	All 0's	N/A	N/A

### E1 USER SETTINGS VS CLOCK STATUS & ASSOCIATED SIGNAL CONDITIONS

USER SETTINGS	CLOCK STATUS	OUTPUT SIGNAL		
FRAMING/ALARM	ALARM STATE	FRAMING	SSM STATE	SSM Message
UNFRAMED ALARM: N/A	NONE	All 1's	N/A	N/A
	MAJOR (BLUE)	All 1's	N/A	N/A
	CRITICAL	All 0's	N/A	N/A
FAS DF ALARM: NONE	NONE	FAS DF	N/A	N/A
	MAJOR (BLUE)	FAS DF	N/A	N/A
	CRITICAL	All 0's	N/A	N/A
FAS DF ALARM: AIS	NONE	FAS DF	N/A	N/A
	MAJOR (BLUE)	AIS(All 1's)	N/A	N/A
	CRITICAL	All 0's	N/A	N/A
CRC4 MF ALARM: NONE	NONE	CRC4 MF	G.811 Synchronization	0010
	MAJOR (BLUE)	CRC4 MF	G.811 Synchronization	0010
	CRITICAL	All 0's	N/A	N/A
CRC4 MF ALARM: AIS	NONE	CRC4 MF	G.811 Synchronization	0010
	MAJOR (BLUE)	AIS(All 1's)	N/A	N/A
	CRITICAL	All 0's	N/A	N/A
CRC4 MF ALARM: SSM	NONE	CRC4 MF	G.811 Synchronization	0010
	MAJOR (BLUE)	CRC4 MF	Do Not Use For Synchronization	1111
	CRITICAL	All 0's	N/A	N/A

### 64kCC USER SETTINGS VS CLOCK STATUS & ASSOCIATED SIGNAL CONDITIONS

USER SETTINGS	CLOCK STATUS	OUTPUT SIGNAL	
LINE CODE/ALARM	ALARM STATE	CODE	
AMI ALARM: N/A	NONE	AMI - All 1's	
	MAJOR (BLUE)	AMI - All 1's	
	CRITICAL	All 0's	
AMI w/ 8kHz BPV ALARM: NONE	NONE	AMI - All 1's w/ 8kHz Bi-Polar Violation	
	MAJOR (BLUE)	AMI - All 1's w/ 8kHz Bi-Polar Violation	
	CRITICAL	All 0's	
AMI w/ 8kHz BPV ALARM: AIS	NONE	AMI - All 1's w/ 8kHz Bi-Polar Violation	
	MAJOR (BLUE)	AMI - All 1's	
	CRITICAL	All 0's	
AMI w/ 8kHz BPV + 400Hz non-BPV ALARM: NONE	NONE	AMI - All 1's w/ 8kHz Bi-Polar Violation + 400Hz non-Violation	
	MAJOR (BLUE)	AMI - All 1's w/ 8kHz Bi-Polar Violation + 400Hz non-Violation	
	CRITICAL	All 0's	
AMI w/ 8kHz BPV + 400Hz non-BPV ALARM: AIS	NONE	AMI - All 1's w/ 8kHz Bi-Polar Violation + 400Hz non-Violation	
	MAJOR (BLUE)	AMI - All 1's	
	CRITICAL	All 0's	

**Alarms**

Minor, Major and Critical Alarms are defined below. For further information on each fault refer to the **cdmastat** command (FLTS field) in *Chapter 4 - Control and Status Commands*. In addition to the fault types listed below, there will be a Critical Alarm if a serious hardware problem is detected on the Telecom Clock Module or the CPU Module.

Fault Type	Critical	Major	Minor
DAC Control Over-Range			X
No Signal Time-Out		X	
FPGA Configuration Fault	X		
FLASH Write Fault	X		
Local Oscillator Fault	X		
Time Input Fault		X	
No Polling Events		X	
Antenna Fault			X
Power A Fault (option)			X
Power B Fault (option)			X
MTIE Exceeds 1 Microsecond*		X	

\*The first 10 faults listed above are standard system faults. When the telecom board is installed, an additional fault detection algorithm is active that compares the worst case holdover accuracy to the telecom industry standard jitter/wander performance masks. This is the last fault listed in the table above (MTIE Exceeds 1 Microsecond).

The following chart shows the G.823 and T1.101 jitter/wander MTIE mask levels that are pertinent to the telecom option module. In addition, it shows the specified worst case accumulated time error, while in holdover, for the various oscillator options that can be installed with the telecom option. Since the one microsecond level is a good approximate level to the various masks, it is also the threshold level that will induce an immediate fault on the telecom option alarm relays and SSM bits. This level is factory configured and not user settable.

If the Meridian loses CDMA signal lock then it will drift at a rate dependent upon the installed oscillator. When it has drifted more than 1 microsecond the MTIE fault will be set and a Major Alarm will occur. The list below summarizes the chart data. It shows how long in holdover each oscillator will be until it exceeds the one microsecond threshold:

- Medium-Stability OCXO: 1 hour
- High-Stability OCXO: 3 hours
- Ultra-Stable OCXO: 6 hours
- Rubidium: 6 hours
- Ultra-Stable Rubidium: 1 day

**EndRun Disciplined Oscillator Holdover Performance  
vs G.823 and T1.101 Jitter/Wander Masks**

5° C Max Delta in Holdover, 7.5° C/hr Max Slewrate

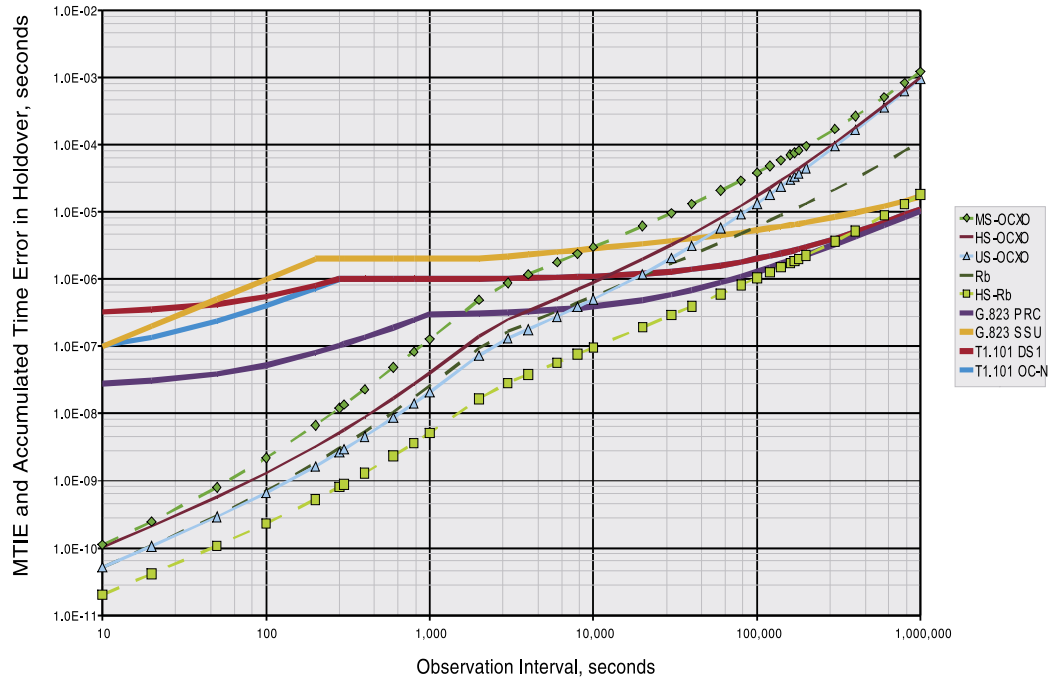

**Connectors and Cables**

The Telecom Clock Module is available with two types of output connectors: BNC and RJ48C. The BNC connector is compatible with 75 ohm coaxial cable. The RJ48C connector is compatible with 100-133 ohm twisted pair. Pin assignments are:

**BNC Pinouts**

BNC CONNECTOR	SIGNAL
CENTER PIN	XMIT TIP (+SIG)
BARREL	XMIT RING (GND)

**RJ48C Pinouts**

RJ48C CONNECTOR	SIGNAL
PIN 1	NO CONNECTION
PIN 2	NO CONNECTION
PIN 3	NO CONNECTION
PIN 4	XMIT RING (-SIG)
PIN 5	XMIT TIP (+SIG)
PIN 6	NO CONNECTION
PIN 7	NO CONNECTION
PIN 8	NO CONNECTION

The RJ48C connector is physically identical to an RJ45 connector. The RJ48C designation refers to the interconnection and pairing within the applicable cable, which is different than that of Ethernet cables. The RJ48C wiring pattern is shown below:

**RJ48C/RJ48C Crossover Cable Connections / Connector Pin-out**

RJ48C SIGNAL	PIN	CABLE WIRE	PIN	RJ48C SIGNAL
RCV RING (-SIG)	1	PAIR 1 RING	4	XMIT RING (-SIG)
RCV TIP (+SIG)	2	PAIR 1 TIP	5	XMIT TIP (+SIG)
NO CONNECTION	3	NONE	3	NO CONNECTION
XMIT RING (-SIG)	4	PAIR 2 RING	1	RCV RING (-SIG)
XMIT TIP (+SIG)	5	PAIR 2 TIP	2	RCV TIP (+SIG)
NO CONNECTION	6	NONE	3	NO CONNECTION
SHIELD GROUND	7	DRAIN WIRE	7	SHIELD GROUND
SHIELD GROUND	8	DRAIN WIRE	8	SHIELD GROUND



**Connection to RJ48C BITS Clock Input**

A crossover cable, as shown above, would be used to connect the EndRun Technologies clock buffer output on RJ48C pins 4 and 5 to equipment with the BITS clock input on RJ48C pins 1 and 2. Equipment with the BITS clock input on pins 4 and 5 would require a straight-through cable. The shield ground is connected on pins 7 and 8.

**Connection to Wire-Wrap Terminal BITS Clock Input**

Use a RJ48C cable with 22 AWG solid wire for connection to wire-wrap terminals. Either connector can be cut off to expose the individual twisted-pairs for this application. Determine the color-coding of the twisted-pair connected to pins 4 and 5 of the remaining RJ48C connector. The wire connected to pin 4 connects to the BITS clock Ring input wire-wrap terminal and the wire connected to pin 5 connects to the BITS clock Tip input wire-wrap terminal. The drain wire associated with that shielded twisted pair connects to the GROUND terminal.

**Shield Ground Connection**

The shield ground should be connected to minimize cross-talk. Connection to BITS clock inputs conforming to the pin-out described in Table 1 or connection as described for wire-wrap inputs will result in a grounded shield. However, some RJ48C BITS clock inputs are wired with the shield connections on pins 3 and 6. This situation can be accommodated by modification or replacement the EndRun-supplied cable. This is compatible with the EndRun Technologies RJ48C clock output connector in which pins 4 and 5 provide the BITS clock signal, while pins 1, 2, 3, 6, 7, and 8 are not connected.

**Cable (655 ft maximum)**

A 10 ft. T1 crossover cable, manufactured by Stonewall Cable (P/N SC-9598-X) is a good cable for initial testing and typical T1, E1, or 64kCC installations. For other lengths or connector configurations, use equivalent T1 or E1 cable qualified to match clock-type. T1 cable is compatible with E1 signals for short runs. Over 10 ft. use cable specified to match the application. Either cable type can be used for 64kCC signals.

# Chapter Seven

## HTTP Interface

*This chapter briefly describes the HTTP interface that resides on the Meridian CDMA Frequency Reference. The HTTP interface to the Meridian is a fast and easy-to-use graphical interface that is compliant with your standard web browser. Simply point your browser to the IP address of the Meridian and login securely with HTTP. Security-conscious customers may disable the HTTP interface (see the end of this appendix for instructions). Note: The HTTP interface is not IPv6-compliant.*

The HTTP interface is not available in older Meridian models. If you have an older model you may want to contact EndRun for information on how to upgrade your Meridian to be HTTP-capable. The older models have a Linux Subsystem root file system (RFS) number of 6010-0042-000. To see the number go to Firmware on the front-panel display or enter the `csysversion` command via the network/serial port. The newer Meridian models have (or can have) the HTTP interface capability. These models have a Linux Subsystem RFS number of 6010-0044-000.

The HTTP implementation in the Meridian uses HTTPS (HTTP over SSL). Secure Socket Layer (SSL) is a sublayer under regular HTTP. HTTPS enhances security because it encrypts and decrypts the requested and returned pages from the server.

The HTTP implementation is built from the standard Apache/1.3.33 distribution from:

<http://httpd.apache.org>

See *Appendix D - Security* for information on changing the default HTTP configuration and SSL certificates.

### IMPORTANT

The domain name server IP address is required by the Apache web server. When using `netconfig` (see *Chapter 4 - Control and Status Commands*) to configure the TCP/IP parameters be sure to configure the name server. Only one name server is required, two gives some redundancy. The HTTP Interface will not start if this is configured incorrectly.

## HTTP Interface Description

For security reasons the web pages on the Meridian show status information only. You cannot re-configure the Meridian except for upgrading firmware, which is done with several security measures in place. To reconfigure the Meridian you will need to use the network or serial port command line interface.

### NOTE

For proper operation, your web browser must be configured to allow pop-up windows and have Javascript enabled.

To get started with the web interface simply point your browser to the IP address of the Meridian and log in securely with HTTP. For example:

`http://192.168.1.1`

A warning dialog page will be presented for the certificate. Acknowledge the dialog page and the server will continue to load, protected by SSL. The browser should display the “Lock” icon, indicating that the page is protected by SSL. To maximize security you should replace the SSL Certificate. See *Appendix D - Security, HTTP* for details.

Below is a picture of the login page:

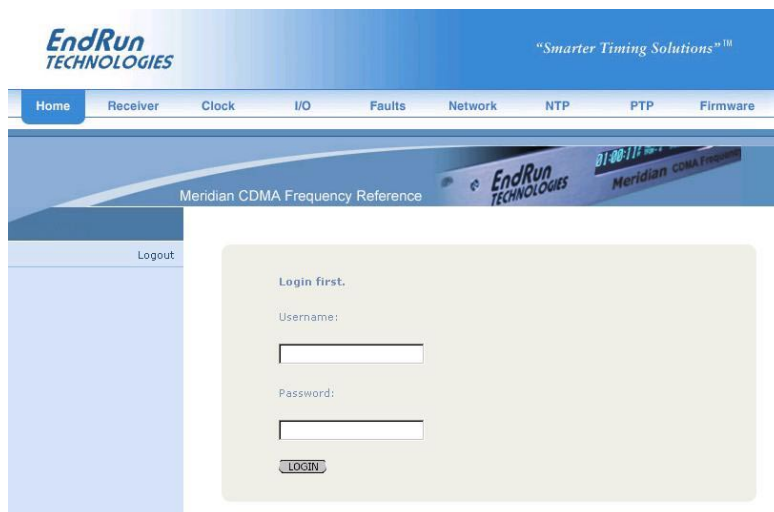

### Navigation

The main menu tabs across the top of each webpage allow you to navigate through the status information in the Meridian while links on the lefthand side of each webpage provide subcategory navigation.

For example, in the page below the main menu tabs are: Home, Receiver, Clock, I/O, Faults, Network, NTP, PTP and Firmware. The subcategory links on this particular page are: IPv4, IPv6 and DNS. IPv4 is selected.

## HTTP INTERFACE

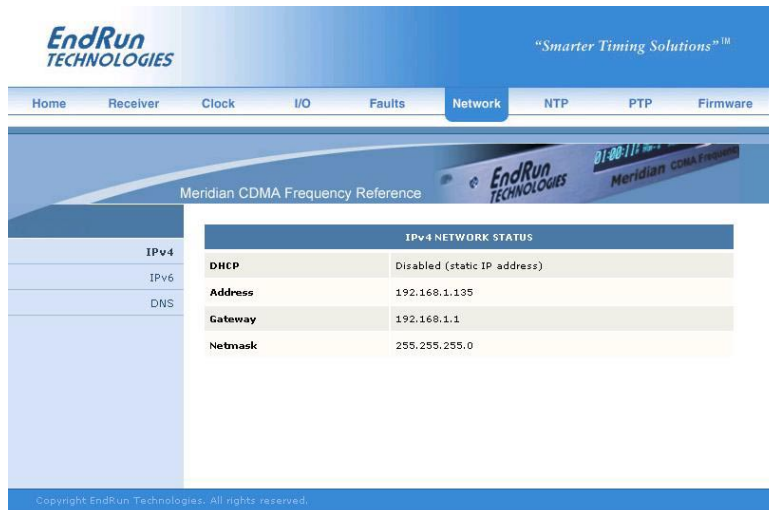

The top-hand tabs and left-side links are logically arranged for easy navigation. The following table defines this relationship:

Tab	Information	Links
Home	Overall Meridian Status Information	Login, Logout
Receiver	CDMA Receiver Status	Receiver, Oscillator
Clock	Clock Status	
I/O	I/O Status (Options)	CPU Options, Plug-In Options
Faults	Fault Status	
Network	Ipv4 Network Status	IPv4, IPv6, DNS
NTP	NTP Status	
PTP	PTP/IEEE-1588 Status (Option)	
Firmware	Firmware Information	Firmware Status, Linux Subsystem Upgrade, CDMA Subsystem Upgrade, Reboot

## Page Descriptions

### Home Page

This page contains general status information. Data fields are:

#### UTC Time

Shows the current hours, minutes and seconds in UTC.

#### Date

Shows the current UTC date.

#### Receiver

Shows whether the CDMA receiver is locked or not.

**TFOM**

Shows the current TFOM value. See *Appendix A - Time Figure of Merit* for more information.

**System Status**

Shows if any system fault is present. If a system fault exists, go to the Faults Page to see which fault it is.

**Receiver Page**

This page contains information related to the CDMA Receiver. Data fields are:

**State**

Shows whether the CDMA receiver is locked or not.

**TFOM**

Shows the current TFOM value. See *Appendix A - Time Figure of Merit* for more information.

**AGC**

This is the automatic gain control (AGC) DAC byte, 0 to 255, with larger numbers implying higher RF gain. With good signal conditions this value is typically 150 to 220.

**SNR**

The signal-to-noise (SNR) ratio is an indicator of the CDMA signal quality. This number must typically be greater than 2.5 for the instrument to acquire a signal. But once it has locked, it can maintain lock at levels down to about 2.0.

**Frame Error Rate**

The number shown represents the sync channel frame error rate, 0.000 to 1.000, with a higher number implying more Cyclical Redundancy Check (CRC) failures. Higher numbers will correlate with lower signal-to-noise ratios.

**PNO**

This is the pseudonoise offset, 0 to 511 in units of 64 pseudonoise code chips. Each base station in an area has a different PNO.

**Channel**

This is the CDMA frequency channel being used. There are eight possible cellular channels and 42 possible PCS channels. Units configured for operation in Japan have two possible cellular channels.

**Channel Set**

This shows the current CDMA channelset being used by the CDMA receiver. It can be one of: North America Cellular, Korea Cellular, North America PCS, India Cellular, or Japan Cellular.

**Signal Fault Mask**

This field shows the current setting for the Signal Alarm Mask. When the signal alarm is masked it will prevent a signal loss fault from creating an alarm condition. Some installations may need to mask this fault when operating the NTP server as a Stratum 2 server. To change the signal alarm mask use the `setsigfltmask` command.

**TFOM Fault Level**

This field shows the threshold at which a signal loss fault will be asserted. See *Appendix A - Time*



*Figure of Merit* for more information. You can change the TFOM Fault Level by using command **settfomflt1vl1**. By changing the TFOM Fault Level you control the point at which the time error will produce a signal loss fault, which then creates an alarm condition. The factory default setting is 9.

### **Clock Calibration**

This field shows the clock calibration delay which is used to advance or retard the clock in order to compensate for antenna cable length or other external hardware. Use the **setcdmacaldelay** command to change this setting.

### **Receiver (Oscillator) Page**

This page shows receiver oscillator control information such as:

#### **Oscillator Type**

This field shows the oscillator type that is installed in the Meridian. It can be one of: TCXO, MS-OCXO, HS-OCXO, US-OCXO, Rubidium or HS-Rubidium.

#### **DAC**

Is the upper 16 bits of the oscillator voltage control DAC word, 0 to 65535, with larger numbers implying higher oscillator frequency. Typical range is 20000 to 38000.

#### **Measured Time Error**

The measured time error is the last measured time offset while locked.

#### **Time Deviation**

This field shows the time deviation (TDEV) of measurements.

#### **Oscillator Ageing Rate**

This field shows the regression computed oscillator ageing rate per day. There is a several-hour delay before the first measurement is shown.

#### **Control Loop TAU**

This is the oscillator control loop averaging time constant.

#### **Coast Duration**

The coast duration is the number of seconds in coast mode (unlocked).

#### **Estimated Time Error**

This field shows the estimated time error when in coast mode.

#### **Internal Chassis Temperature**

This field shows the internal temperature in °C.

### **Clock Page**

This page shows the configuration of the Meridian except for any optional I/O which is listed on the I/O page. Fields are:

#### **Time Mode**

This field shows the current time mode setting. Possible settings are UTC, GPS, Local-auto and Local-manual. This setting will affect the time displayed on the front-panel display, the AM Code

Output (time code) and any optional Serial Time Output. It will not affect the NTP output, which is always UTC. To change the time mode setting use the front-panel keypad/display or the **csys-timemodeconfig** command via the network/serial port. Note: Local-auto derives the local offset and DST from the information embedded in the CDMA timing signal. Local-manual derives the local offset and DST from information entered by the user.

**Local Time Offset**

This field shows the offset from UTC and is only valid when the Time Mode is Local. A positive Local Time Offset implies a longitude east of the Greenwich meridian. To change the local offset use the **csystemtimemodeconfig** command.

**Hour Display Format**

This field shows the format used for the time on the front-panel display. Options are 24 Hour Mode and 12 Hour Mode.

**Keypad Lockout**

This field shows whether the front-panel keypad is locked or not. Changing the keypad lockout can only be done through the network/serial port command line. To change use the **lockoutkp** or **unlockkp** commands.

**Daylight Savings Time (DST), DST Start, DST End**

The DST fields show whether DST is enabled and if so, what the DST Start and End Times are. For example, in most of the U.S.A. the DST Start Time is the 2nd Sunday in March at 2 a.m. The DST End Time is the 1st Sunday in November at 2 a.m. To change the DST settings use the front-panel keypad/display or the **csystemtimemodeconfig** command.

**Leap Second Mode, Current Leap Seconds, Future Leap Seconds**

Leap seconds affect NTP, UTC and Local Time (not GPS Time). Leap second insertions occur about once every two years. The Meridian has two different modes for handling leap seconds. In automatic leap second mode, the Leap Second Mode field will show Automatic and the Current & Future fields will show the current and future leap seconds as broadcast over the CDMA system. In user-entered leap second mode, the Leap Second Mode field will show User-Entered.

To change the leap second settings, use the front-panel keypad/display or the **cdmaleapconfig** command.

The Meridian is shipped from the factory set for the user-entered mode with current and future leap seconds set appropriately. You will need to change this setting the next time a leap second is pending. Refer to *Appendix H - Leap Seconds* for further information.

**I/O Page**

This page shows the installed CPU Module options and their settings. These are all outputs generated from the CPU Module in the Meridian. On the Meridian/Tempus platform these outputs are called “options” but in actuality, the 1PPS Output and AM Code Output (time code) are standard outputs in the Meridian. Other possible CPU Module options are a Programmable TTL Output and a Serial Time Output. Use commands **cpuoptsconfig** and **cpusertimeconfig** via the network/serial port to change the settings of the CPU Options.

**I/O Page (Plug-In Options)**

This page shows any installed Plug-In Modules and their settings. Some plug-in modules can be user-configured. Use command **pluginoptsconfig** to change the configuration of these modules.

**Faults Page**

This page lists all possible fault conditions of the CDMA Subsystem. The various faults are described below:

**FLASH**

This fault indicates that the microprocessor was unable to verify a write to the FLASH non-volatile parameter storage area. This should not ever occur under normal operation. The unit should be returned to the factory for repair.

**FPGA**

This fault indicates that the microprocessor was unable to configure the FPGA. This would be a fatal fault and the unit should be returned to the factory for repair .

**Signal**

This fault indicates that the unit has not been able to acquire a CDMA signal for one hour while the Time Figure of Merit has been 9, the unsynchronized condition. This could be due to a variety of reasons. If there are no other faults that could explain the inability to receive a signal, then there could be an or antenna failure or blockage. If the condition persists indefinitely, and a problem with the antenna is not evident, the unit may need to be returned to the factory for repair.

**DAC**

This fault indicates that the electronic frequency control DAC for the oscillator has reached either the high (55000) or low (10000) limit while locked to the CDMA signal. Unless the unit is being subjected to out-of-specification environmental conditions, this would indicate that the oscillator frequency has drifted near to the end of life region. This should normally only occur after about ten years of operation. The unit will continue to function until the oscillator frequency finally reaches one of the actual DAC endpoints. The unit should be returned to the factory for oscillator replacement at the your convenience.

**Polling Events**

This fault indicates that the CDMA Subsystem is not receiving polling request from the Linux Subsystem. This could be due to a hardware or software failure. If the condition persists after cycling the power to the unit, this is a fatal fault and the unit should be returned to the factory for repair.

**Time Reference**

This fault indicates that the microprocessor received an erroneous time input from the CDMA Subsystem. Do NOT reset the unit in an attempt to clear this fault. If the condition persists please report it to the factory (1-877-749-3878).

**Synthesizer**

This fault indicates that the Local Oscillator Phase Locked Loop (PLL) synthesizer is either unlcked or has failed. This condition should not normally occur unless the unit is subject to out-of-specification environmental conditions. Otherwise, this would be a fatal fault and the unit should be returned to the factory for repair.

**Primary Power Fault**

This fault is only used if the Meridian is configured with dual redundant power supplies. It indicates the operational status of the primary supply regardless of whether it is supplying the internal chassis power.

**Secondary Power Fault**

This fault is only used if the Meridian is configured with dual redundant power supplies. It indicates the operational status of the secondary supply regardless of whether it is supplying the internal chassis power.

**Network Page**

This page shows the IPv4 network configuration. Fields are:

**DHCP**

By default, the Meridian will configure itself using the Dynamic Host Configuration Protocol (DHCP). If you need to set up static IP configuration, you must use the `netconfig` command via the network/serial port. This field will show whether DHCP is enabled or disabled.

**Address, Gateway, Netmask**

These fields show the settings for the IP address, gateway and netmask. To change these settings use the `netconfig` command via the network/serial port.

**Network (IPv6) Page**

This page shows information related to the IPv6 network parameters. If your Meridian does not have IPv6 then there will be no fields on this page. For more information on IPv6 see *Appendix I - IPv6 Information*.

**Network (DNS) Page**

This page shows the IP address of the primary and secondary domain name servers.

**NTP Page**

The NTP Status page shows all information related to NTP operation. Fields are:

**Status**

The stratum field has three possible values:

- Stratum 1: The server is fully synchronized and accurate.
- Stratum 2: The server is synchronized to a Stratum 1 server.
- Stratum 16: The server is unsynchronized. NTP clients will not use a Stratum 16 server.

**Source**

This field will show the source of time which is usually CDMA. If the Meridian is configured as a Stratum 2 server then it will show the IP address of the upstream server.

**Offset**

This field shows the offset in seconds between the NTP system clock and the CDMA Subsystem clock. Positive implies that the NTP system clock is ahead of the CDMA Subsystem clock.

**Leap Indicator Bits**

This field shows whether a leap second is pending. Leap seconds occur every 2-3 years. Possible values for this field are: NONE, INSERT, DELETE or FAULT.

---

## HTTP INTERFACE

NONE:	No fault and no pending leap second.
INSERT	No fault and a leap second insertion is pending.
DELETE	No fault and a leap second deletion is pending.
FAULT	Unsynchronized fault condition exists.

### PTP Page

The fields on this page show the status for the optional PTP/IEEE-1588 protocol. If your Meridian does not have PTP then there will be no information on this page. The data shown will depend on whether PTPv1 or PTPv2 has been selected. For more information on PTP and an explanation of the data fields on this page see *Appendix K - Precision Time Protocol (PTP) IEEE-1588*.

### Firmware Page

The firmware status page shows part numbers and versions of the Linux Subsystem firmware (root file system and kernel) and the CDMA Subsystem firmware.

### Linux Subsystem Upgrade, CDMA Subsystem Upgrade

These pages are used for upgrading the firmware. You must be logged in as “root” in order to have access to these pages. The latest released versions of Meridian firmware are freely available on the EndRun website. For detailed information on how to perform the upgrade either via the network port, the serial port, or the web interface see *Appendix B - Upgrading The Firmware*. Only the Linux Subsystem root file system (RFS) and the CDMA Subsystem can be upgraded via the HTTP interface. To upgrade the Linux Subsystem kernel see *Appendix B - Upgrading the Firmware, Performing the Linux Kernel Upgrade*.

### Reboot

This page will allow you to perform a software reboot of both the Linux Subsystem and the CDMA Subsystem. This is normally used after a firmware upgrade but can be done anytime you wish to reset the Meridian.

## Disabling The HTTP Protocol

To disable HTTP you need to edit a system start-up script called */etc/rc.d/rc.local*. This script starts several daemons. You can either remove the line that lists HTTP or you can place a # character at the beginning of the line so that it will not be executed. (A very compact editor is available on the system for this purpose: **edit**. If you start **edit** without giving it a file name to open, it will display its help screen, showing the supported keystrokes.)

### IMPORTANT

After editing */etc/rc.d/rc.local*, you must copy it to the */boot/etc/rc.d* directory and reboot the system. It is very important to retain the access mode for the file, so be sure to use **cp -p** when performing the copy. During the boot process, the files contained in the */boot/etc/rc.d* directory are copied to the working */etc/rc.d* directory on the system RAM disk. In this way the factory defaults are overwritten.



# Appendix A

## Time Figure-of-Merit (TFOM)

This appendix describes the Time Figure of Merit (TFOM) number. The TFOM is printed out in the time-of-day field printed by the Meridian `cdmastat` command (see Chapter 3). The TFOM number indicates the level of accuracy that should be included in the interpretation of the time-of-day and ranges from 6 to 9:

6	time error is < 100 microseconds
7	time error is < 1 milliseconds
8	time error is < 10 milliseconds
9	time error is > 10 milliseconds, unsynchronized state if never locked to CDMA

In all cases, the Meridian reports this value as accurately as possible, even during periods of CDMA signal outage where the Meridian is unable to directly measure the relationship of its timing outputs to UTC. During these CDMA outage periods, assuming that the Meridian had been synchronized prior to the outage, the Meridian extrapolates the expected drift of the Meridian timing signals based on its knowledge of the characteristics of the internal Temperature Compensated Crystal Oscillator (TCXO), Oven Controlled Crystal Oscillator (OCXO) or Rubidium oscillator. The extrapolated TFOM is based on a conservative estimate of the performance of the oscillator and should be considered 'worst case' for a typical benign ambient temperature environment.

During periods of signal loss, the CDMA Subsystem will compute an extrapolated worst case time error as described above. If the signal loss condition persists you will see the TFOM character change to indicate a gradually deteriorating accuracy of the timing outputs. One hour after the worst case time error has reached the value equivalent to a TFOM of TFOM Fault Level, the red LED will illuminate. The fault status field returned in the `cdmastat` command will have the appropriate bit set to indicate a loss-of-signal time-out condition.

You may control the TFOM level at which a loss-of-signal alarm is generated by changing the TFOM Fault Level. This can be done through the front-panel keypad/display (see *Chapter 3 - Front-Panel Keypad and Display*) or through the console port (see the `settfomflt1vl1` and `tfomflt1vl1` commands in *Chapter 4 - Control and Status Commands*). The factory default setting for the TFOM Fault Level is 9.

The TFOM Fault Level setting only affects the point at which the loss-of-signal alarm is asserted. It does not affect the point at which the NTP daemon will cease to use the timing information returned by the CDMA Subsystem in its polling event timestamps. Only when the TFOM reaches 9 will the NTP daemon report in its replies to network NTP clients that it is running at stratum 16 and set the leap indicator bits to the fault state. NTP clients will recognize that and cease to use the unsynchronized server.





# Appendix B

## Upgrading the Firmware

Periodically, EndRun Technologies will make bug fixes and enhancements to our products available for download from our website. All such downloads are freely available to our customers, without charge. You may securely upgrade your Meridian firmware via the HTTP interface, the network port, or the serial port. Software upgrades for the Meridian are available at this link:

<http://www.endruntechnologies.com/upgrademer.htm>

### Upgrade Via The HTTP Interface

The HTTP interface is not available in the older Meridian models. These models have a Linux Subsystem part number of 6010-0042-000. To see the software part number go to Firmware on the front-panel display or enter the `csysversion` command via the network/serial port. If you have one of the older Meridian models please proceed to the next section - *Upgrade Via The Network/Serial Port*.

The newer Meridian models have (or can have) the HTTP interface capability. These models have a Linux Subsystem part number of 6010-0044-000. The HTTP interface was introduced at version 5.50 of the Linux Subsystem software. If you have one of the newer Meridian models and your current software version is at least 5.50, you may upgrade firmware via the web interface or the network/serial port command line interface.

Software upgrades via the HTTP interface are simple, with your choice of two methods:

1. If your Meridian has access to the internet, the HTTP interface can automatically retrieve the appropriate files from the FTP server at [endruntechnologies.com](http://endruntechnologies.com) to temporary locations on the Meridian. You will need to authenticate the root user name and password, and follow the prompts from the HTTP interface to complete each upgrade, one for the Linux Subsystem and the other for the CDMA Subsystem.

#### IMPORTANT

The domain name server IP address is required by the Apache web server. When using `netconfig` (see *Chapter 4 - Control and Status Commands*) to configure the TCP/IP parameters be sure to configure the name server. Only one name server is required, two gives some redundancy. The HTTP Interface will not start if this is configured incorrectly.

The following picture shows the Linux Subsystem RFS Upgrade page. All fields are filled in with default values to download the appropriate software image from the EndRun Technologies website. You can use these default values unless you want to point to a different FTP server.

The screenshot shows the EndRun Technologies website with a navigation menu including Home, Receiver, Clock, I/O, Faults, Network, NTP, PTP, and Firmware. The Firmware section is active, displaying a sidebar with options: Firmware Status, Linux RFS Upgrade (highlighted), CDMA Subsystem Upgrade, and Reboot. The main content area is titled 'Upgrade from a FTP server.' and contains the following form fields:

- File Name:
- FTP Server Name:
- FTP Login Name:
- FTP Login Password:
- 

2. If your Meridian does not have access to the internet, you must first download the appropriate files from the endruntechnologies.com website to the computer that you will be using later to access the Meridian via its HTTP interface. Use the link shown above to get the files. After saving the files, use the Meridian HTTP interface to select the previously saved files for upload to the Meridian. One for the Linux Subsystem and the other for the CDMA Subsystem. Then follow the remaining prompts from the HTTP interface to complete the upgrades. (You will need to authenticate the root user name and password.)

The screenshot shows a web form titled 'Upgrade from a local file that was previously downloaded from endruntechnologies.com'. It features a file selection field with a 'Browse...' button, a 'SUBMIT' button, and a message: 'Please wait after pressing Submit. This may take about 60 seconds.'

## Upgrade Via The Network/Serial Port

In order to upgrade via the network or serial ports you will need to first download the appropriate FLASH binary image file from the EndRun website. After you have done this you are ready to upgrade your Meridian. The firmware consists of two FLASH binary image files. One of these is the firmware for the Meridian Linux Subsystem. This firmware executes on the IBM-compatible CPU and contains the embedded Linux operating system and application software. The other file is the firmware for the CDMA Subsystem. Each of these files may be upgraded independently, although some upgrades require both images to be modified together.

You will need to use **ftp** or **scp** to transfer the binary image file(s) to the Meridian. This means that you must place the previously downloaded file(s) in a place on your network which is accessible to the Meridian.

### Performing the Linux Subsystem Upgrade

There are two FLASH disk partitions which hold the compressed Linux root file system images. These partitions are raw FLASH blocks, have no file system and may not be mounted. They are accessed through low-level devices. To protect the factory root file system from accidental erasure or over-writing, the device node has been deleted. The upgrade FLASH disk partition is accessed via `/dev/rootfs_1`. When performing an upgrade, you will be copying the new image to this device.

#### CAUTION

Some browsers will automatically unzip the file when downloading from the website. Please make sure that the downloaded file size matches what the website says it should be. Upgrading the partition with a too-large file size will cause problems.

To perform the upgrade, log in as the `root` user to the Meridian using the local console serial I/O port, `telnet` or `ssh` and perform these operations:

First erase the upgrade partition by issuing this command at the shell prompt:

```
eraserootfs_1
```

If you are using **ftp** to perform the upgrade, transfer the previously downloaded file using *binary* transfer mode from the remote host to `/dev/rootfs_1` on your Meridian using FTP. The root file system image will be named with the software part number and version like: `6010-004x-000_3.00.gz`. When following the instructions below, substitute the name of the actual root file system image that you are installing for `6010-004x-000_3.00.gz`. Issue these commands from the console of your Meridian:

```
ftp remote_host           {perform ftp login on remote host}
bin                       {set transfer mode to binary}
get 6010-004x-000_3.00.gz /dev/rootfs_1 {transfer the file}
quit                      {close the ftp session after transfer }
```

If you are using **ssh**, you may open a command window on the remote computer and securely transfer the root file system image using **scp** from the remote computer to your Meridian. A command like this should be used:

```
scp -p 6010-004x-000_3.00.gz root@csys.your.domain:/dev/rootfs_1
```

Update the default file system partition by issuing this command on your Meridian.

```
updaterootflag 1
```

You should see this line displayed:

```
UPGRADE is the default root file system.
```

Now reboot the system by issuing this command at the shell prompt:

```
shutdown -r now
```

Wait about 90 seconds for the system to shutdown and reboot. Then log in to the Meridian using **telnet** or **ssh**. If all has gone well, you should be able to log in the usual way. After you have entered your password, the system message will be displayed. You should notice that it now indicates the software version and date of the upgrade that you previously downloaded. You can also check this at any time by issuing

```
csysversion
```

which will cause the system message to be re-displayed.

You can also check to see which root file system image the system is currently booted under by issuing this command at the shell prompt:

```
csysrootfs
```

Which should cause this to be printed to the console:

```
BOOT_IMAGE=MeridianCDMA_1
```

If so, and your unit seems to be operating normally, you have successfully completed the upgrade. If your unit does not boot up successfully, and you are not able to **telnet** or **ssh** into the system after 90 seconds, then there has been some kind of problem with the upgrade. It is possible that the file downloaded was corrupt or that you forgot to set your FTP download file mode to binary when downloading the file--either from the EndRun Technologies website or when transferring it to the Meridian.

#### **Recovering from a Failed Upgrade**

To restore your Meridian to a bootable state using the factory root file system, you must use the serial I/O port and reboot the Meridian by cycling the power. Refer to *Chapter 2 – Connect the Serial I/O Port and Test the Serial I/O Port* for setup details. When you have connected your terminal to the serial I/O port, apply power to the Meridian.

Pay close attention to the terminal window while the unit is rebooting. After the Linux bootloader displays the message

To override and boot the **FACTORY** partition type **'FACTORY'** within 5 seconds...

you must begin typing “factory” within five seconds to let the bootloader know that you are going to override the default root file system. After you hit <enter> the bootloader will boot the factory root file system. Watch the rest of the boot process to make sure that you have successfully recovered. If the system boots normally, then you should resolve the problems with the previous upgrade and re-perform it.

### Performing the Linux Kernel Upgrade

The Meridian is shipped from the factory with a kernel that is IPv4-only capable only. If you want to upgrade your kernel to the IPv4/IPv6-capable one then you must first be sure that your root file system is version 2.60 or later. To see the root file system version type **csysversion** at the network/serial port.

To upgrade your kernel, log in as the *root* user to the Meridian using the local console serial I/O port, **telnet** or **ssh** and perform these operations:

If you are using **ftp** to perform the upgrade, transfer the previously downloaded file using *binary* transfer mode from the remote host to a temporary location on your Meridian using FTP. The IPv6 kernel image will be named with the software part number like: *6010-0041-100.bzimage*. When following the instructions below, substitute the name of the actual kernel image that you are installing for *6010-0041-100.bzimage*. Issue these commands from the console of your Meridian:

```
ftp remote_host           {perform ftp login on remote host}
bin                       {set transfer mode to binary}
get 6010-0041-100.bzimage /tmp {transfer the file}
quit                      {close the ftp session after transfer }
```

If you are using **ssh**, you may open a command window on the remote computer and securely transfer the root file system image using **scp** from the remote computer to your Meridian. A command like this should be used:

```
scp -p 6010-0041-100.bzimage root@csys.your.domain:/tmp
```

The kernel upgrade utility is executed with a single argument passed on the command line: the path to the previously uploaded kernel image file. For example:

```
upgradkernel /tmp/6010-0041-100.bzimage
```

The kernel upgrade utility verifies the integrity of the file, reads the kernel version information, presents it to you and asks you to verify before replacing the old kernel image. If you verify, it will then erase the old image and write the new one in its place. The erase and write operation takes about 10 seconds.

### CAUTION

A power failure during the kernel erase and write operation would render your unit unbootable. It is highly advisable to plug your unit into a UPS while performing the kernel upgrade.

### Performing the CDMA Subsystem Upgrade

To perform this upgrade, log in as the *root* user to the Meridian using either the local console serial I/O port, **telnet** or **ssh** and perform these operations:

Change the working directory to the */tmp* directory:

```
cd /tmp
```

If you are using **ftp** to perform the upgrade, transfer the previously downloaded file using *binary* transfer mode from the remote host to the working directory, */tmp*. The CDMA Subsystem image will be named with the software part number and version like: *6010-0020-000\_3.01.bin*. When following the instructions below, substitute the name of the actual CDMA Subsystem image that you are installing for *6010-0020-000\_3.01.bin*:

```
ftp remote_host           {perform ftp login on remote host}
bin                       {set transfer mode to binary}
get 6010-0020-000_3.01.bin {transfer the file}
quit                      {close the ftp session after the transfer }
```

If you are using **ssh**, you may open another command window on the remote computer and securely transfer the CDMA Subsystem image to the */tmp* directory using **scp** from the remote computer. A command like this could be used:

```
scp -p 6010-0020-000_3.01.bin root@csys.your.domain:/tmp
```

Now issue the following command to the Meridian console to initiate the upload:

```
upgradecdma /tmp/6010-0020-000_3.01.bin
```

This command is a script that performs the file transfer to the CDMA Subsystem. It first tells the CDMA Subsystem to enter the ‘waiting for download’ mode, and then prompts you with this line

```
---When you see the `C` character, hit <enter> to begin the upload.
```

Then it echos the serial port characters sent by the CDMA Subsystem to the console. You should next see this message from the CDMA Subsystem:

```
Waiting for download using XMODEM 128 or XMODEM 1K (both with CRC).
Control X will abort download.
```

After about 3 seconds, you should see a capital ‘C’ character appear. When you do, hit the <enter> key. Now the script will initiate the XMODEM file transfer and display this message to the console:

```
---Starting file upload, should take about 90 seconds...
```

After about one minute you should see this message from the script:

```
/sbin/upgradecdma: line 26: 27618 Terminated          cat </dev/arm_user
```

```
---You should see the CDMA sub-system startup message now. If not, you
---may need to check your binary file and re-perform the procedure.
```

The first message should be ignored. It is only reporting that one of the intermediate processes of the script execution has been terminated. The next message informs you that the CDMA Subsystem file

transfer has completed, and that its start-up messages should appear. First the bootloader message will appear:

```
Tempus Bootloader 6010-0050-000 v 1.00 - May 28 2004 17:31:05
```

In about ten seconds, the CDMA Subsystem application start-up messages should appear:

```
FW 6010-0020-000 v 1.00 - Aug 18 2004 10:47:41
FPGA 6020-0005-000 v 0202
```

The firmware version should match that of the binary file that you uploaded. At this point, the **upgradedcdma** script terminates its execution, and you will again have the standard Meridian console prompt.

After about one minute, you should query the CDMA firmware version using the command:

```
cdmaversion
```

The upgraded version information should be displayed.

### Problems with the CDMA Subsystem Upgrade

Should you have difficulties with the upgrade due to a corrupt file, power failure during upload, or other accident, do not be alarmed. Even though you may have lost the existing application program, the CDMA Subsystem bootloader program will remain intact. On boot up, it will check to see if a valid application program is in the FLASH memory. If there is not, it will immediately go into the 'waiting for download' mode. You may verify this by issuing this command:

```
cat < /dev/arm_user
```

You should now see the 'C' character being received every three seconds. This is the character that the CDMA Subsystem bootloader sends to indicate to the XMODEM utility that it is waiting for a download. You may now retry the upload procedure, assuming that you have corrected any original problem with the binary file. First kill the **cat** command by typing CTRL-C. You should see a command prompt. Now issue this command to re-transfer the binary file:

```
upgradedcdma /tmp/6010-0020-000_3.01.bin
```

### Recover Command

Sometimes a user will attempt to download the wrong file to the CDMA Subsystem. When this happens the recovery method above will not work. After issuing the **cat** command above you will not see a series of "C" characters, but instead you will see the bootloader message being output every few seconds. In this case you need to use a different recovery procedure.

First make sure the above **cat** command is killed by typing CTRL-C. Then enter a new **cat** command as:

```
cat < /dev/arm_user &
```

You should again be seeing the bootloader message every few seconds:

```
Tempus Bootloader 6010-0050-000 v 1.00 - May 28 2004 17:31:05
```

---

## APPENDIX B

Please type the following command but do not press enter:

```
echo -e "recover\r" > /dev/arm_user
```

Now wait until you see another bootloader message come out and then press enter. You will then see the "C" come out every 3 seconds. You then kill the previous **cat** command by entering:

```
kill $!
```

You should see a command prompt. Now issue this command to re-transfer the correct binary file:

```
upgradecdma /tmp/6010-0020-000_3.01.bin
```



# Appendix C

## *Simple Network Management Protocol (SNMP)*

Your Meridian includes the (NET)-SNMP version 5.3.1 implementation of an SNMP agent, **snmpd**, and a SNMP notification/trap generation utility, **snmptrap**. It supports all versions of the protocol in use today: SNMPv1 (the original Internet standard), SNMPv2c (never reached standard status, often called “community SNMP”) and SNMPv3 (the latest Internet standard).

The NET-SNMP project has its roots in the Carnegie-Mellon University SNMP implementation. For more detailed information about the NET-SNMP project and to obtain management software and detailed configuration information, you can visit this website: <http://www.net-snmp.org>.

An excellent book which describes operation and configuration of various SNMP managers and agents, including the NET-SNMP implementations, is available from O’Reilly & Associates:

*Essential SNMP*, Mauro & Schmidt, O’Reilly & Associates, 2001

If you are planning to operate with SNMPv3, it is highly recommended that you make use of both of these resources to familiarize yourself with the agent configuration concepts.

### **SNMPv3 Security**

Prior to SNMPv3, SNMP had definite security inadequacies due to using two community names in a manner analogous to passwords that were transmitted over the network as clear text. In addition, since no mechanism existed for authenticating or encrypting session data, any number of man-in-the-middle data corruption/replacement exploits were possible in addition to plain old snooping to learn the community names. SNMPv3 implements the User-based Security Model (USM) defined in RFC-2274 which employs modern cryptographic technologies to both authenticate multiple users and to encrypt their session data for privacy, much in the same way that SSH does for remote login shell users.

In addition, it implements the View-based Access Control Model (VACM) defined in RFC-2275. This RFC defines mechanisms for limiting the access of multiple users having various security levels (no authentication, authentication or authentication plus privacy) to specific “views” of the Structure of Management Information (SMI) object tree.

### **Enterprise Management Information Base (MIB)**

In addition to providing the SNMP variables contained in MIB-II as described in RFC-1213, EndRun Technologies has implemented an enterprise MIB using the syntax of the SMI version 2 (SMIv2) as described in RFC-2578:

## MERIDIAN-MIB

Which is located on your Meridian in this ASCII file:

```
/usr/local/share/snmp/mibs/MERIDIAN-MIB.txt
```

In addition to a complete set of NTP and CDMA status objects, the MIB defines four SMIv2 notification objects:

- NTP Leap Indicator Bits status change
- NTP Stratum change
- CDMA Fault Status change
- CDMA Time Figure of Merit change

## Invocation of the SNMP daemon

The SNMP daemon, `snmpd` is started from the `/etc/rc.d/rc.local` system start-up script with this line:

```
snmpd -m "$MIBNAME" -Ls d -c /etc/snmpd.conf
```

By default, it will listen on port 161 for SNMP queries from the network management system. If you would like to have it listen on another port, you could edit the file by adding `-p port` to the end of this line, where `port` is the number of the port you would like for the agent to listen on. If you would like to disable starting of the `snmpd` daemon altogether, you can either remove this line or place a `#` character at the beginning of the line so that it will not be executed. (A very compact editor with WordStar command keystrokes is available on the system for this purpose: `edit`. If you start `edit` without giving it a file name to open, it will display its help screen, showing the supported keystrokes.)

### IMPORTANT

After editing `/etc/rc.d/rc.local`, you must copy it to the `/boot/etc/rc.d` directory and reboot the system. It is very important to retain the access mode for the file, so be sure to use `cp -p` when performing the copy. During the boot process, the files contained in the `/boot/etc/rc.d` directory are copied to the working `/etc/rc.d` directory on the system RAM disk. In this way the factory defaults are overwritten.

## Quick Start Configuration -- SNMPv1/v2c

You should be able to compile the MERIDIAN-MIB file on your SNMP management system and access the variables defined therein. The factory default community names are “MeridianCDMA” for the read-only community and “endrun\_1” for the read-write community. This is all that is required for operation under v1 and v2c of SNMP.

### Change Default Community Strings (Passwords)

To ensure security, you should change the default community names by editing */etc/snmpd.conf* and modifying these two lines:

```
rwcommunity   endrun_1
rocommunity   MeridianCDMA
```

## Configuring SNMPv1 Trap Generation

To have your Meridian send SNMPv1 traps (RFC-1215) you must configure the community and destination for SNMPv1 traps by uncommenting and editing this line in */etc/snmpd.conf*:

```
trapsink      xxx.xxx.xxx.xxx trapcommunity trapport
```

where **trapcommunity** should be replaced by your community, and **xxx.xxx.xxx.xxx** is the IP address or hostname of the destination host for receiving the traps generated by the Meridian. By default, the trap will be sent to port 162. You may optionally add another parameter, **trapport** to the end of the above line to override the default port setting. Otherwise leave it blank.

Note: Though the agent will recognize multiple **trapsink** lines within */etc/snmpd.conf* and send the generic SNMP coldStart or authenticationFailure traps to each destination, the enterprise trap generation mechanism of the Meridian will only send a trap to the last declared **trapsink** in the file.

## Configuring SNMPv2c Notifications and Informs

To have your Meridian send SNMPv2c notifications (SMIV2, RFC-2578) or informs, you must configure the communities and destinations by uncommenting and editing one or both of these lines in */etc/snmpd.conf*:

```
trap2sink     xxx.xxx.xxx.xxx trap2community trap2port
informsink    xxx.xxx.xxx.xxx informcommunity informport
```

where **trap2community** and **informcommunity** should be replaced by your communities, and **xxx.xxx.xxx.xxx** is the IP address or hostname of the destination host for receiving the notifications or informs generated by the Meridian. By default, the v2c trap or inform will be sent to port 162. You may optionally add another parameter, **trap2port** or **informport** to the ends of the above lines to override the default port setting. Otherwise leave it blank.

Note: Though the agent will recognize multiple **trap2sink** or **informsink** lines within */etc/snmpd.conf* and send the generic SNMP coldStart or authenticationFailure notifications and informs to each destination, the enterprise notification/inform generation mechanism of the Meridian will only send a notification to the last declared **trap2sink** and an inform to the last declared **informsink** in the file.

**IMPORTANT**

After editing */etc/snmpd.conf*, you must copy it to the */boot/etc* directory and reboot the system. It is very important to retain the access mode for the file (readable only by *root*), so be sure to use `cp -p` when performing the copy. During the boot process, the files contained in the */boot/etc* directory are copied to the working */etc* directory on the system RAM disk. In this way the factory defaults are overwritten.

**Configuration of SNMPv3**

If you are planning to use SNMPv3, you should definitely make use of the two resources mentioned previously (NET-SNMP website and *Essential SNMP*) and study them carefully. There are rather elaborate configuration options available when you are using v3. The instruction presented here will give you the flavor of the configuration but definitely not the full scope of possibilities. To access your Meridian via v3 of SNMP, you will have to configure two files:

```
/etc/snmpd.conf
/boot/net-snmp/snmpd.conf
```

The first file contains static configuration parameters that the agent uses to control access and to determine where to send notifications/traps. Other aspects of the agent's operation are also configurable in this file, but you should not need to modify those. To use the SNMPv3 capabilities of the Meridian, you must first set up user information and access limits for those users in */etc/snmpd.conf*. Uncomment and edit these two lines to define your v3 users and their access parameters:

```
rwuser root      priv .1
rouser meridianuser auth .1.3.6.1.4.1.13827
```

The first line defines a SNMPv3 read-write user *root* whose minimum security level will be authenticated and encrypted for privacy (choices are noauth, auth and priv), and who will have read-write access to the entire *iso(1)* branch of the SMI object tree. The second line defines a SNMPv3 read-only user *meridianuser* whose minimum security level will be authenticated but not encrypted, and who will have read-only access to the entire *iso(1).org(3).dod(6).internet(1).private(4).enterprises(1).endRunTechnologiesMIB(13827)* branch of the SMI object tree. After adding the user lines to */etc/snmpd.conf*, copy it to the */boot/etc* directory using `cp -p`.

The second file is located on the non-volatile FLASH disk and is used by the SNMP agent to store "persistent data" that may be dynamic in nature. This may include the values of the MIB-II variables *sysLocation*, *sysContact* and *sysName* as well as any configured SNMPv3 user crypto keys. In order to use SNMPv3, you must configure user keys in this file for each SNMPv3 user that you have set up in */etc/snmpd.conf*. To do this, you must add lines to */boot/net-snmp/snmpd.conf* like these for each user:

```
createUser root      MD5 endrun_1 DES endrun_1
createUser meridianuser SHA MeridianCDMA
```

The first line will cause the agent, *snmpd* to create a user *root* who may be authenticated via Message Digest Algorithm 5 (MD5) with password *endrun\_1* and may use the Data Encryption Standard (DES) to encrypt the session data with passphrase *endrun\_1*. The second line will cause a user *meridianuser* to be created who may be authenticated using the Secure Hash Algorithm (SHA) with

password *MeridianCDMA*. Passwords and passphrases must have a *minimum* of 8 characters, or you will not be able to be authenticated.

### IMPORTANT

You must kill the `snmpd` process prior to editing, `/boot/net-snmplib/snmpd.conf`. Otherwise, the secret key creation may not complete properly. Issue the command `ps -e` to have the operating system display the list of running processes. Look for the PID of the `snmpd` process and issue the kill command to stop it. For example, if the PID listed for the `snmpd` process is 53, then you would issue this command: `kill 53`. You can verify that the process was terminated by re-issuing the `ps -e` command.

After rebooting, the agent will read the `/boot/net-snmplib/snmpd.conf` configuration file and compute secret key(s) for each of the users and delete the `createUser` lines from the file. It will then write the secret key(s) to the file. These lines begin with the string, `usmUser`. In this way, un-encrypted passwords are not stored on the system.

### IMPORTANT

To generate new keys, stop the `snmpd` process, delete the existing `usmUser` key lines from the file `/boot/net-snmplib/snmpd.conf` and then add new `createUser` lines. Then reboot the system.

This example gives the simplest configuration to begin using SNMPv3 but doesn't make use of the full capabilities of the VACM in defining groups and views for fine-grained access control. The factory default `/etc/snmpd.conf` file contains commented blocks of lines that can be uncommented to give you a basic configuration that uses the User-based Security Model (USM) described in RFC-2274 and the View-based Access Control Model (VACM) described in RFC-2275. The comments included in the file should help you in modifying it for your specific requirements.

## Disabling The SNMP Protocol

To disable SNMP you need to edit a system start-up script called `/etc/rc.d/rc.local`. This script starts several daemons. You can either remove the line that lists SNMP or you can place a `#` character at the beginning of the line so that it will not be executed. (A very compact editor is available on the Meridian system called `edit`. If you start `edit` without giving it a file name to open, it will display its help screen, showing all supported editing keystrokes.)

### IMPORTANT

After editing `/etc/rc.d/rc.local`, you must copy it to the `/boot/etc/rc.d` directory and reboot the system. It is very important to retain the access mode for the file, so be sure to use `cp -p` when performing the copy. During the boot process, the files contained in the `/boot/etc/rc.d` directory are copied to the working `/etc/rc.d` directory on the system RAM disk. In this way the factory defaults are overwritten.



# Appendix D

## Security

Your Meridian incorporates several important security features to prevent unauthorized tampering with its operation. Many of these are standard multiple-user access control features of the underlying Linux operating system which controls the Meridian. Others are provided by the additional protocol servers selected for inclusion in your Meridian, and the way that they are configured.

Secure user authentication and session privacy while performing routine monitoring and maintenance tasks are provided by the OpenSSH implementations of the “secure shell” daemon, `sshd` and its companion “secure copy” utility, `scp`. The Apache implementation of the Hyper Text Transport Protocol (HTTP) with Secure Sockets Layer (SSL) daemon (`httpd`) provides for a secure, encrypted session with a digital certificate. The NET-SNMP implementation of the Simple Network Management Protocol (SNMP) daemon, `snmpd` conforms to the latest Internet standard, known as SNMPv3, which also supports secure user authentication and session privacy. In addition, the Network Time Protocol daemon, `ntpd` supports client-server authentication security measures to deter spoofing of NTP clients by rogue NTP servers. This appendix describes these security measures and gives the advanced network administrator information that will allow custom configuration to fit specific security needs.

### IMPORTANT

SSH, Telnet, SNMP and HTTP are all enabled with default passwords. To ensure security, change the passwords or disable the protocols. To change the passwords for SSH, Telnet and HTTP use the `csyspasswd` command. To change the passwords/community strings for SNMP see **Appendix C - SNMP**.

By default all users are allowed access via SSH, Telnet and SNMP. To restrict access via these protocols, use the `accessconfig` command or edit `/etc/hosts.allow` and `/etc/hosts.deny`. All users are allowed access via HTTP as well. To restrict access via HTTP, edit `/etc/apache/httpd.conf` to set up access by specific hosts.

To completely disable any or all of these protocols see **Disabling Protocols** below.

## Linux Operating System

The embedded Linux operating system running in the Meridian is based on kernel version 2.4.31 and version 10 of the Slackware Linux distribution. As such it supports a complete set of security provisions:

- System passwords are kept in an encrypted file, `/etc/shadow` which is not accessible by users other than `root`.
- Direct `root` logins are only permitted on the local RS-232 console or via SSH.

- The secure copy utility, **scp**, eliminates the need to use the insecure **ftp** protocol for transferring program updates to the Meridian.
- HTTP may be completely disabled by configuration of */etc/rc.d/rc.local*.
- Access via SNMP is configurable to provide the security of the latest version 3 Internet standard which supports both view-based access control and user-based security using modern encryption techniques. Previous versions v1 and v2c supported access control essentially via passwords transmitted over the network in plain text. Refer to *Appendix C – Simple Network Management Protocol* which is dedicated to configuration of SNMP for details.
- Individual host access to protocol server daemons such as **in.telnetd**, **snmpd** or **sshd** may be controlled by the **tcpd** daemon and directives contained in the files */etc/hosts.allow* and */etc/hosts.deny*.
- Risky protocols like TIME, DAYTIME and TELNET may be completely disabled by configuration of the **inetd** super-server daemon.

The last two topics are supported on the Meridian by a pair of shell scripts which ease configuration for the inexperienced user of Unix-like operating systems. These are **accessconfig** and **inetd-config**.

### Using Edit

A very compact editor is available on the system for editing files: **edit**. If you start **edit** without giving it a file name to open, it will display its help screen, showing all supported keystrokes.

## Limiting Access

By default, the unit is configured to allow access by all users via Telnet, SSH and SNMP. To ensure security you should restrict access by using the **accessconfig** command.

**accessconfig** modifies two files which are used by **tcpd** and the standalone daemons, **snmpd** and **sshd**, to determine whether or not to grant access to a requesting host: */etc/hosts.allow* and */etc/hosts/deny*. These two files may contain configuration information for a number of protocol servers, but in the Meridian only access control to the protocol server daemons **in.telnetd**, **sshd** and **snmpd** is configured.

As shipped from the factory, these two files are empty. When the user runs **accessconfig**, these lines are added to the */etc/hosts.deny* file:

```
in.telnetd: ALL
sshd: ALL
snmpd: ALL
```

This tells **tcpd** to deny access to **in.telnetd** and **sshd** to all hosts not listed in the */etc/hosts.allow* file. The **snmpd** and **sshd** daemons also parse this file prior to granting access to a requesting host. Then the user is prompted to enter a list of hosts that will be granted access to **in.telnetd**, **sshd** and **snmpd**. These appear in the */etc/hosts.allow* as lines like this:



```
in.telnetd: 192.168.1.2, 192.168.1.3
sshd: 192.168.1.2, 192.168.1.3
snmpd: 192.168.1.2, 192.168.1.3
```

This simple shell script handles the needs of most users, however the syntax of these two files supports elaborate configuration possibilities which are beyond the capabilities of this simple shell script. Advanced users who need these capabilities will need to edit these two files directly and then copy them to the */boot/etc* directory. (See *Using Edit* above.) Be careful to maintain the proper ownership and access permissions by using **cp -p** when copying the files.

To control access via HTTP, the user must edit the */etc/apache/httpd.conf* file and add the equivalent deny followed by allow directives. For example, the default file contains these lines:

```
# Controls who can get stuff from this server.
#
    Order allow,deny
    Allow from all
</Directory>
```

To restrict access to a specific host with IP address xxx.xxx.xxx.xxx, you would modify the directives as so:

```
# Controls who can get stuff from this server.
#
    Order allow,deny
    Deny from all
    Allow from xxx.xxx.xxx.xxx
</Directory>
```

## Disabling Protocols

You may completely disable any of the following protocols: Telnet, TIME, DAYTIME, SSH, SNMP and HTTP.

### Disable Telnet, TIME and DAYTIME

To disable Telnet, TIME and DAYTIME use the **inetdconfig** command. **inetdconfig** modifies the */etc/inetd.conf* file which is read by **inetd** to start-up various protocol server daemons when requests from remote hosts are received. Currently, three servers are configurable via **inetdconfig**: TIME and DAYTIME, whose daemons are contained within the **inetd** daemon itself, and **in.telnetd**. Any one or all of these may be enabled or disabled for start-up.

### Disable SNMP and HTTP

To disable SNMP and HTTP, edit a system start-up script called */etc/rc.d/rc.local*. This script starts several of the daemons running on the system. You should follow the instructions contained in comments in the file for disabling the **snmpd** and **httpd** daemons. Placing a **#** character at the beginning of a line makes it a comment line so that it will not be executed. (See *Using Edit* above.)

### Disable SSH

To disable SSH, edit a system start-up script called `/etc/rc.d/rc.inet2`. This script starts several of the daemons running on the system. You should follow the instructions contained in comments in the file for disabling the `sshd` daemon. Placing a `#` character at the beginning of a line makes it a comment line so that it will not be executed. (See *Using Edit* above.)

#### IMPORTANT

After editing `/etc/rc.d/rc.local` and/or `/etc/rc.d/rc.inet2`, you must copy them to the `/boot/etc/rc.d` directory and reboot the system. It is very important to retain the access mode for these files, so be sure to use `cp -p` when performing the copy. During the boot process, the files contained in the `/boot/etc/rc.d` directory are copied to the working `/etc/rc.d` directory on the system RAM disk. In this way the factory defaults are overwritten.

## OpenSSH

The secure shell protocol server running in the Meridian is based on the portable OpenSSH for Linux. As such it supports both SSH1 and SSH2 protocol versions. By default, only SSH2 is enabled due to security issues with SSH1. For more information about this protocol and to obtain client software, refer to the OpenSSH website: <http://www.openssh.com>.

An excellent book which describes operation and configuration of the various SSH implementations, including OpenSSH is available from O'Reilly & Associates:

*SSH, The Secure Shell*, Barrett & Silverman, O'Reilley & Associates, 2001

In the interest of conserving scarce system memory resources, only the secure shell server daemon, `sshd` and the secure copy utility, `scp`, are implemented in the Meridian. This means that users on remote hosts may log in to the Meridian via an `ssh` client, but users logged in on the Meridian are unable to log in to a remote host via `ssh`. Since `scp` runs in concert with an `ssh` client, the same limitations exist for its use, i.e. users on remote hosts may transfer files to and from the Meridian via `scp` over `ssh` but users logged in on the Meridian are unable to transfer files to and from a remote host via `scp` over `ssh`.

The factory configuration contains a complete set of security keys for both SSH1 and SSH2 versions of the protocol. RSA keys are supported by both versions, and DSA keys are supported when using the SSH2 version.

In addition, the Meridian is factory configured with a set of public keys for passwordless, public key authentication of the root user. To use this capability, the corresponding set of private keys for each of the two SSH versions are provided in the `/boot/root` directory of the Meridian. Three files contain these keys: `identity` (SSH1), `id_rsa` (SSH2) and `id_dsa` (SSH2). These must be copied to the user's `root/.ssh` directory on their remote computer. (Be careful to maintain the proper ownership and access permissions by using `cp -p` when copying the files. They MUST be readable only by `root`.) The corresponding public keys are by factory default resident in the `/root/.ssh` directory of the Meridian. Two files contain these keys: `authorized_keys` (SSH1) and `authorized_keys2` (SSH2).

Since the provided private keys are not passphrase protected, the user should create a new set of keys after verifying operation with the factory default key sets. After creating the new keys, the public keys should be copied to the `/boot/root/.ssh` directory of the Meridian. At boot time, the Meridian

will copy these to the actual `/root/.ssh` directory of the system ramdisk, thereby replacing the factory default set of public keys.

Advanced users wishing to modify the configuration of the `sshd` daemon should edit the `/etc/sshd_config` file and then copy it to the `/boot/etc` directory of the Meridian. Be careful to maintain the proper ownership and access permissions by using `cp -p` when copying the file. At boot time, it will be copied to the `/etc` directory of the system ramdisk, thereby replacing the factory default configuration file.

To disable the SSH protocol, see *Disable SSH* above.

## Network Time Protocol

The NTP implementation in the Meridian is built from the standard distribution from the <http://www.ntp.org> site. By factory default, remote control of the NTP daemon `ntpd` is disabled. Query-only operation is supported from the two NTP companion utilities `ntpq` and `ntpdq`.

Control via these two utilities is disabled in the `/etc/ntp.conf` file in two ways. First, MD5 authentication keys are not defined for control operation via a `requestkey` or `controlkey` declaration. Second, this default address restriction line is present in the file:

```
restrict default nomodify
```

This line eliminates control access from ALL hosts. Query access is not affected by this restriction. Knowledgeable NTP users who would like to customize the security aspects of the configuration of the NTP daemon in the Meridian should edit the `/etc/ntp.conf` file directly and then copy it to the `/boot/etc` directory. Be sure to retain the ownership and permissions of the original file by using `cp -p` when performing the copy.

### CAUTION

If you are planning to make changes to the `/etc/ntp.conf` file, you must not restrict query access from the local host to the NTP daemon. Various system monitoring processes running on the system require this access.

An example follows which shows how to restrict query access to a specific remote host with IP address 192.168.1.10 while also allowing processes running on the Meridian to have query access as well:

```
restrict default noquery nomodify
restrict localhost nomodify
restrict 192.168.1.10 nomodify
```

## **HTTP**

The HTTP server in the Meridian is built from the standard Apache/1.3.33 distribution from:

<http://httpd.apache.org>

It uses HTTPS (HTTP over SSL) with `mod_ssl` (the Apache interface to OpenSSL). For more information about this protocol, refer to <http://www.modssl.org>.

HTTP and SSL use two files for the default configuration located in `/etc/apache`. These are `httpd.conf` and `ssl.conf`. Advanced users who need to modify the default configuration will need to edit these two files and copy them to the `/boot/etc/apache` directory. (See *Using Edit* above.)

For SSL it is recommended that new certificates are generated and installed on the Apache web server with `mod_ssl`. The current certificates included are located in `/etc/apache/ssl.ctr`, `/etc/apache/ssl.csr`, and `/etc/apache/ssl.key`. New certificates, CSRs, and private keys will need to be saved in `/boot/etc/apache/ssl.crt`, `/boot/etc/apache/ssl.csr`, and `/boot/etc/apache/ssl.key` directories.

By default, the Apache server configuration file `httpd.conf` for `httpd` is factory-configured. It contains the configuration directives that give the server its instructions. Although not required, the directives may be changed by editing `/etc/apache/httpd.conf`, and then copying it to `/boot/etc/apache`. Do not attempt to change the directives unless you have a real need to do so.

An excellent book which describes operation and configuration of the various HTTP directives and SSL configuration is:

*Professional Apache*, Wainwright, Wrox Press, 1999.

To disable HTTP, see *Disable SNMP and HTTP* above.

# Appendix E

## *Setting Up NTP Clients on Unix-like Platforms*

*To configure your Unix-like computer to use your Meridian NTP interface, you must have successfully configured the Meridian NTP Server as per the instructions in **Chapter 5 - Setting Up The NTP Server**. This manual is not a 'How-To' on installing and using NTP; basic approaches to NTP client configuration for operation with the Meridian will be described. It is expected that you are, or have access to, a capable Unix/Linux system administrator and know more than a little about installing distributions from source code. Installation must be performed by a user with root privileges on the system. If you have never used NTP, then you should spend some time reading the on-line documents, especially the Distribution Notes, FAQ and Configuration subject matter, which are available at: <http://www.ntp.org>*

If you have a news server, many problems may be solved by the helpful people who participate in the Internet news group devoted to NTP at: `comp.protocols.time.ntp`.

Three methods of using the Meridian with NTP clients on Unix-like platforms will be described:

**Basic:** This is the simplest, and will operate without MD5 authentication. **NTP beginners should always perform this setup first.**

**MD5:** This method is trickier only because MD5 keys must be set up and distributed accurately to the NTP clients in a secure way. The Meridian is factory configured to authenticate its replies to NTP MD5 clients using its default set of keys.

**Broadcast/Multicast:** This method simplifies configuration of the clients on large networks since specific server addresses need not be configured in each client's `/etc/ntp.conf` file. It can be configured either with or without MD5 authentication. However, it is highly recommended that authentication be configured when using broadcast/multicast mode due to the relative ease with which a fake NTP server can take over the clock setting of the broadcast/multicast clients on the network.

## Basic NTP Client Setup

Basic setup is relatively simple, if:

- You have been able to successfully communicate with the Meridian on your network.
- You have installed NTP on your client computer.

### Configure NTP

You must edit the *ntp.conf* file which **ntpd**, the NTP daemon, looks for by default in the */etc* directory. Add this line to the *ntp.conf* file:

```
server 192.168.1.245
```

This line tells **ntpd** to use the NTP server at address 192.168.1.245 in addition to any other servers which might also be configured in the client's *ntp.conf* file.

Restart **ntpd** to have it begin using the Meridian server. Use the NTP utility **ntpq** to check that **ntpd** is able to communicate with the Meridian. After issuing the command

```
ntpq
```

you will see the **ntpq** command prompt:

```
ntpq>
```

Use the command

```
peers
```

to display the NTP peers which your computer is using. One of them should be the Meridian server which you have just configured. You should verify that it is being 'reached'. (You may have to continue issuing the **peers** command for a minute or two before you will see the 'reach' count increment.) If you have other peers configured, verify that the offset information for the Meridian server peer and your other peers is in agreement to within a few milliseconds, assuming that the other peers are synchronized to that level of accuracy.

It may also be useful to start the NTP daemon in 'debug' mode (**ntpd -d**) to confirm successful configuration. Refer to the NTP documentation for detailed usage of these debug utilities.

## MD5 Authenticated NTP Client Setup

MD5 authenticated setup is relatively simple, if:

- You have been able to successfully communicate with the Meridian on your network.
- Your Meridian has been configured to perform authentication either by factory default, or by running the **ntpconfig** shell script. The example Meridian authentication configuration shown in *Chapter 5 - Setting Up The NTP Server* will be assumed in the example configuration commands shown here.
- You have installed NTP on your client computer.

- You have successfully performed the *Basic NTP Client Setup* on your client computer.

### Create the `ntp.keys` File

You must create a file named `ntp.keys` in the `/etc` directory. It must be a copy of the one residing in the `/etc` directory of your Meridian. You can `telnet` into your Meridian and start an `ftp` session with your client computer to send the Meridian's `/etc/ntp.keys` file to your client computer, use the secure copy utility `scp`, or you can just use a text editor on your client computer to create an equivalent file.

### IMPORTANT

Handling of the `/etc/ntp.keys` file is the weak link in the MD5 authentication scheme. It is very important that it is owned by `root` and not readable by anyone other than `root`.

After transferring the file by `ftp`, and placing it in the `/etc` directory on the client computer, issue these two commands at the shell prompt:

```
chown root.root /etc/ntp.keys
chmod 600 /etc/ntp.keys
```

### Configure NTP

You must edit the `ntp.conf` file which `ntpd`, the NTP daemon, looks for by default in the `/etc` directory. Assuming that you have created two trusted keys as shown in the example in the previous chapter, add these lines to the end of the `ntp.conf` file:

```
keys /etc/ntp.keys
trustedkey 1 2
```

Modify the line added previously in *Basic NTP Client Setup* so that authentication will be used with the Meridian server using one of the trusted keys, in this case key # 1:

```
server 192.168.1.245 key 1
```

Restart `ntpd` to have it begin using the Meridian server with MD5 authentication. Use the NTP utility `ntpq` to check that `ntpd` is able to communicate with the Meridian. After issuing the command

```
ntpq
```

you will see the `ntpq` command prompt:

```
ntpq>
```

Use the command

```
peers
```

to display the NTP peers which your computer is using. One of them should be the Meridian server which you have just configured. You should verify that it is being 'reached'. (You may have to continue issuing the `peers` command for a minute or two before you will see the 'reach' count increment.)

You can verify that authentication is being used by issuing the command

```
associations
```

to display the characteristics of the client server associations. In the “auth” column of the display, you should see “OK” for the row corresponding to the Meridian server. If you see “bad”, you should wait a few minutes to be sure that there is a problem since “bad” is the initial state of this setting. If the “bad” indication persists then you must check your configuration for errors. Typically this is due to a typing error in creating the `/etc/ntp.keys` file on the client that causes a mismatch between the keys being used by the server and client. (If you transfer the file by `ftp` or `scp`, this shouldn’t be a problem.) It is also possible to have a typing error in the `/etc/ntp.conf` file that causes the needed key to not be included in the “trustedkey” list.

## Broadcast/Multicast NTP Client Setup

Broadcast/multicast client setup is relatively simple, if:

- You have been able to successfully communicate with the Meridian on your network.
- Your Meridian has been configured to perform broadcasts or multicasts via the front-panel keypad or by running the `ntpconfig` shell script. (This is not the factory default configuration, so be sure to run `ntpconfig`.) If you are going to use MD5 authentication, your Meridian must have been configured to operate with authentication in the broadcast/multicast mode, and you must know which of the trusted keys it is using for broadcast/multicast operation. The example Meridian configuration shown in *Chapter 5 - Setting Up the NTP Server* will be assumed in the example configuration commands shown here.
- You have installed NTP on your client computer.
- You have successfully performed the *MD5 Authenticated NTP Client Setup* on your client computer, if you plan to use MD5 authentication.

### Configure NTP Client for Broadcast

You must edit the `ntp.conf` file which `ntpd`, the NTP daemon, looks for by default in the `/etc` directory. Assuming that your Meridian server has been configured to use key 2 for broadcast authentication as shown in the example in chapter 5, make sure that key 2 is included in the `trustedkey` line, and add this line to the end of the `ntp.conf` file:

```
broadcastclient
```

If you are not using MD5 authentication, you would add these lines:

```
disable auth
broadcastclient
```

You may remove the line added previously in *Basic NTP Client Setup*:

```
server 192.168.1.245
```

or the authenticated version added in *MD5 Authenticated NTP Client Setup*:



```
server 192.168.1.245 key 1
```

### Configure NTP Client for Multicast

You must edit the *ntp.conf* file which **ntpd**, the NTP daemon, looks for by default in the */etc* directory. And add these lines for multicast:

```
multicastclient 224.0.1.1
```

or for IPv6:

```
multicastclient ff05::101
```

If you are not using MD5 authentication, you would add these lines:

```
disable auth
multicastclient 224.0.1.1
```

or for IPv6:

```
disable auth
multicastclient ff05::101
```

You may remove the line added previously in *Basic NTP Client Setup*:

```
server 192.168.1.245
```

or the authenticated version added in *MD5 Authenticated NTP Client Setup*:

```
server 192.168.1.245 key 1
```

### Test Broadcast/Multicast

Restart **ntpd** to have it begin using the Meridian as a broadcast or multicast server. Use the NTP utility **ntpq** to check that **ntpd** is able to communicate with the Meridian. After issuing the command

```
ntpq
```

you will see the **ntpq** command prompt:

```
ntpq>
```

Use the command

```
peers
```

to display the NTP peers which your computer is using. One of them should be the Meridian server which you have just configured. You should verify that it is being 'reached'. (You may have to continue issuing the **peers** command for a minute or two before you will see the 'reach' count increment.)

If you are using authentication, you can verify that authentication is being used by issuing the command

```
associations
```

to display the characteristics of the client server associations. In the “auth” column of the display, you should see “OK” for the row corresponding to the Meridian server. If you see “bad”, you should wait a few minutes to be sure that there is a problem since “bad” is the initial state of this setting. If the “bad” indication persists then you must check your configuration for errors. Typically this is due to a typing error in creating the */etc/ntp.keys* file on the client that causes a mismatch between the keys being used by the server and client. (If you transfer the file by **ftp** or **scp**, this shouldn’t be a problem.) It is also possible to have a typing error in the */etc/ntp.conf* file that causes the needed key to not be included in the “trustedkey” list.

# Appendix F

## *Setting Up NTP Clients on Windows NT 4.0/2000/XP*

*To configure your Windows NT 4.0/2000/XP computer to use your Meridian NTP interface, you must have successfully configured the Meridian NTP Server as per the instructions in **Chapter 5 - Setting Up the NTP Server**. This manual is not a 'How-To' on installing and using NTP; basic approaches to NTP configuration for operation with the Meridian will be described here. Installation must be performed by a user with administrative privileges on the system. If you have never used NTP, then you should spend some time reading the on-line documents at: <http://www.ntp.org>.*

If you have a news server, many problems may be solved by the helpful people who participate in the Internet news group devoted to NTP at: [comp.protocols.time.ntp](mailto:comp.protocols.time.ntp).

Three methods of using the Meridian with NTP clients on Window NT 4.0 platforms will be described:

**Basic:** This is the simplest, and will operate without MD5 authentication. **NTP beginners should always perform this setup first.**

**MD5:** This method is trickier only because MD5 keys must be set up and distributed accurately to the NTP clients in a secure way. The Meridian is factory configured to authenticate its replies to NTP MD5 clients using its default set of keys.

**Broadcast/Multicast:** This method simplifies configuration of the clients on large networks since specific server addresses need not be configured in each client's `\winnt\system32\drivers\etc\ntp.conf` file. It can be configured either with or without MD5 authentication. However, it is highly recommended that authentication be configured when using broadcast /multicast mode due to the relative ease with which a fake NTP server can take over the clock setting of the broadcast/multicast clients on the network.

## Basic NTP Client Setup

Basic setup is relatively simple, if:

- You have been able to successfully communicate with the Meridian on your network.
- You have installed NTP on your client computer.

### Configure NTP

You must edit the *ntp.conf* file which **ntpd.exe**, the NTP daemon, looks for by default in the the *\winnt\system32\drivers\etc* directory of the boot partition. If your NTP installation placed this file in a different place, you must find it and edit it. For example, XP uses *\windows\system32\drivers\etc*. Add this line to the *ntp.conf* file:

```
server 192.168.1.245
```

This line tells **ntpd.exe** to use the NTP server at address 192.168.1.245 in addition to any other servers which might also be configured in the *ntp.conf* file.

Restart **ntpd.exe** to have it begin using the Meridian server. By default, the NTP installation program installs **ntpd.exe** as a service called Network Time Protocol, and starts it. You must use the Services utility in Control Panel to stop the Network Time Protocol service and then restart it.

Use the NTP utility **ntpq.exe** to check that **ntpd.exe** is able to communicate with the Meridian. By default it is installed in the *\Program Files\Network Time Protocol* sub-directory of your Windows NT/2000/XP partition. From a console window, after issuing the command

```
ntpq
```

you will see the **ntpq.exe** command prompt:

```
ntpq>
```

Use the command

```
peers
```

to display the NTP peers which your computer is using. One of them should be the Meridian server which you have just configured. You should verify that it is being 'reached'. (You may have to continue issuing the peers command for a minute or two before you will see the 'reach' count increment.) If you have other peers configured, verify that the offset information for the Meridian server peer and your other peers is in agreement to within a few milliseconds, assuming that the other peers are synchronized to that level of accuracy.

It may also be useful to start the NTP daemon in 'debug' mode (**ntpd -d**) to confirm successful configuration. The debug version of the NTP daemon is located in the *debug* sub-directory of your NTP directory. Refer to the NTP documentation for detailed usage of these debug utilities.

## MD5 Authenticated NTP Client Setup

MD5 authenticated setup is relatively simple, if:

- You have been able to successfully communicate with the Meridian on your network.
- Your Meridian has been configured to perform authentication either by factory default, or by running the `ntpconfig` shell script. The example Meridian authentication configuration shown in *Chapter 5 - Setting Up the NTP Server* will be assumed in the example configuration commands shown here.
- You have installed NTP on your client computer.
- You have successfully performed the *Basic NTP Client Setup* on your client computer.

### Create the `ntp.keys` File

You must create a file named `ntp.keys` in the `\winnt\system32\drivers\etc` directory or, for XP, the `\windows\system32\drivers\etc` directory. It must be a copy of the one residing in the `/etc` directory of your Meridian. You can `telnet` into your Meridian and start an `ftp` session with your client computer to send the Meridian `/etc/ntp.keys` file to your client computer, or use the secure copy utility `scp`, or use a text editor to create the equivalent file. Although you should first test your setup using the factory default `/etc/ntp.keys` file in your Meridian server, you should create your own keys after you understand the process and have your clients operating correctly with the default file.

### IMPORTANT

Handling of the `\windows\system32\drivers\etc\ntp.keys` file is the weak link in the MD5 authentication scheme. It is very important that it is owned by "administrator" and not readable by anyone other than "administrator".

After transferring the file, make sure that its security properties are set such that it is readable only by the "administrator".

### Configure NTP

You must edit the `ntp.conf` file which `ntpd.exe`, the NTP daemon, looks for by default in the `\winnt\system32\drivers\etc` directory. If your NTP installation placed this file in a different place, you must find it and edit it. For example, XP uses `\windows\system32\drivers\etc`. Add these lines to the end of the `ntp.conf` file:

```
keys \winnt\system32\drivers\etc\ntp.keys
trustedkey 1 2
```

Modify the line added previously in *Basic NTP Client Setup* so that authentication will be used with the Meridian server using one of the trusted keys, in this case key # 1:

```
server 192.168.1.245 key 1
```

Restart `ntpd.exe` to have it begin using the Meridian server with MD5 authentication. By default,

the NTP installation program installs **ntpd.exe** as a service called Network Time Protocol, and starts it. You must use the Services utility in Control Panel to stop the Network Time Protocol service and then restart it.

Use the NTP utility **ntpq.exe** to check that **ntpd.exe** is able to communicate with the Meridian. By default it is installed in the *\Program Files\Network Time Protocol* sub-directory of your Windows NT/2000/XP partition. From a console window, after issuing the command

```
ntpq
```

you will see the **ntpq.exe** command prompt:

```
ntpq>
```

Use the command

```
peers
```

to display the NTP peers which your computer is using. One of them should be the Meridian server which you have just configured. You should verify that it is being ‘reached’. (You may have to continue issuing the peers command for a minute or two before you will see the ‘reach’ count increment.)

You can verify that authentication is being used by issuing the command

```
associations
```

to display the characteristics of the client server associations. In the “auth” column of the display, you should see “OK” for the row corresponding to the Meridian server. If you see “bad”, you should wait a few minutes to be sure that there is a problem since “bad” is the initial state of this setting. If the “bad” indication persists then you must check your configuration for errors. Typically this is due to a typing error in creating the *\winnt\system32\drivers\etc\ntp.keys* file on the client that causes a mismatch between the keys being used by the server and client. (If you transfer the file by **ftp** or **scp**, this shouldn’t be a problem.) It is also possible to have a typing error in the *\winnt\system32\drivers\etc\ntp.conf* file that causes the needed key to not be included in the “trustedkey” list.

## **Broadcast/Multicast NTP Client Setup**

Broadcast/multicast client setup is relatively simple, if:

- You have been able to successfully communicate with the Meridian on your network.
- Your Meridian has been configured to perform broadcasts or multicasts via the front-panel keypad or by running the **ntpconfig** shell script. (This is not the factory default configuration, so be sure to run **ntpconfig**.) If you are going to use MD5 authentication, your Meridian must have been configured to operate with authentication in the broadcast/multicast mode, and you must know which of the trusted keys it is using for broadcast/multicast operation. The example Meridian configuration shown in *Chapter 5 - Setting Up the NTP Server* will be assumed in the example configuration commands shown here.
- You have installed NTP on your client computer.

- You have successfully performed the *MD5 Authenticated NTP Client Setup* on your client computer, if you plan to use MD5 authentication.

### Configure NTP Client for Broadcast

You must edit the *ntp.conf* file which **ntpd.exe**, the NTP daemon, looks for by default in the the `\winnt\system32\drivers\etc` directory or, for XP, the `\windows\system32\drivers\etc` directory. Assuming that your Meridian server has been configured to use key 2 for broadcast authentication as shown in the example in chapter 5, make sure that key 2 is included in the **trustedkey** line, and add this line to the end of the *ntp.conf* file:

```
broadcastclient
```

If you are not using MD5 authentication, you would add these lines:

```
disable auth  
broadcastclient
```

You may remove the line added previously in *Basic NTP Client Setup*:

```
server 192.168.1.245
```

or the authenticated version added in *MD5 Authenticated NTP Client Setup*:

```
server 192.168.1.245 key 1
```

### Configure NTP Client for Multicast

You must edit the *ntp.conf* file which **ntpd.exe**, the NTP daemon, looks for by default in the the `\winnt\system32\drivers\etc` directory or, for XP, the `\windows\system32\drivers\etc` directory. Assuming that your Meridian server has been configured to use key 2 for broadcast authentication as shown in the example in chapter 5, make sure that key 2 is included in the **trustedkey** line, and add this line to the end of the *ntp.conf* file:

```
multicastclient 224.0.1.1
```

or for IPv6:

```
multicastclient ff05::101
```

If you are not using MD5 authentication, you would add these lines:

```
disable auth  
multicastclient 224.0.1.1
```

or for IPv6:

```
disable auth  
multicastclient ff05::101
```

You may remove the line added previously in *Basic NTP Client Setup*:

```
server 192.168.1.245
```

or the authenticated version added in *MD5 Authenticated NTP Client Setup*:

```
server 192.168.1.245 key 1
```

**Test Broadcast/Multicast**

Restart **ntpd.exe** to have it begin using the Meridian as a broadcast or multicast server. By default, the NTP installation program installs **ntpd.exe** as a service called Network Time Protocol, and starts it. You must use the Services utility in Control Panel to stop the Network Time Protocol service and then restart it.

Use the NTP utility **ntpq.exe** to check that **ntpd.exe** is able to communicate with the Meridian. By default it is installed in the *\Program Files\Network Time Protocol* sub-directory of your Windows NT/2000/XP partition. After issuing the command

```
ntpq
```

you will see the **ntpq.exe** command prompt:

```
ntpq>
```

Use the command

```
peers
```

to display the NTP peers which your computer is using. One of them should be the Meridian server which you have just configured. You should verify that it is being 'reached'. (You may have to continue issuing the peers command for a minute or two before you will see the 'reach' count increment.)

If you are using authentication, you can verify that authentication is being used by issuing the command

```
associations
```

to display the characteristics of the client server associations. In the "auth" column of the display, you should see "OK" for the row corresponding to the Meridian server. If you see "bad", you should wait a few minutes to be sure that there is a problem since "bad" is the initial state of this setting. If the "bad" indication persists then you must check your configuration for errors. Typically this is due to a typing error in creating the *\windows\system32\drivers\etc\ntp.keys* file on the client that causes a mismatch between the keys being used by the server and client. (If you transfer the file by **ftp** or **scp**, this shouldn't be a problem.) It is also possible to have a typing error in the *\windows\system32\drivers\etc\ntp.conf* file that causes the needed key to not be included in the "trustedkey" list.



# Appendix G

## Time Code Formats

A standard feature of your Meridian is a single time code output available at the rear panel BNC connector identified as AM CODE. A DC-shift time code output is available via the optional Programmable TTL Output on the CPU Module (see **CPU Module Options** in **Chapter 6 - Optional Rear-Panel Outputs**). Multiple time code outputs (both AM and DC-shift) are also available via an option board module (see **Plug-In Module Options** in **Chapter 6**).

The output code format is selectable via the front-panel user interface. See **Time Code Output Setup** in **Chapter 3 - Front-Panel Keypad and Display**. You can also select the time code format via a console command. See **CpuOptsConfig** in **Chapter 4 - Control and Status Commands**. Each format is described below. Time codes are commonly used to provide time information to external devices such as displays, magnetic tape devices, strip chart recorders and several types of embedded computer peripheral cards.

### **IRIG-B122/002**

This is the most widely used format and is normally the factory default for the AM Code output. The IRIG-B122 format is a 100 pps code and is used to amplitude modulate a 1000 kHz sine wave carrier. The information contained in the time code is seconds through day-of-year coded in Binary Coded Decimal (BCD). Reference IRIG Document 104-60.

### **IRIG-B123/003**

In addition to the time information identified in B122 above, this format also contains Straight Binary Seconds (SBS) of day. SBS is provided at the end of the frame, in the 17 bits starting in position 80.

### **IRIG-B120/000 (IEEE-Standard 1344-1995)**

In addition to the time data and the Straight Binary Seconds data this format provides for time/status data in the control bit positions of IRIG-B. The information provided there is defined by IEEE standard 1344-1995: Unit and Tens of Years, Leap Second, Daylight Savings, Local Time Offset, Time Quality and Parity. The IEEE-1344 table provided below shows each bit position with detailed information.

### **NASA-36**

NASA-36 bit time code is a 100-bit, pulse width modulated format used to amplitude modulate a 1000 kHz sine wave carrier. The information contained in the time code is seconds, minutes, hours and days. The format is used by several military ranges. Reference IRIG Document 104-59.

### **2137**

The 2137 code is a 25-bit pulse width modulated format used to amplitude modulate a 1000 kHz sine wave carrier. The information contained in the time code is seconds, minutes and hours. The format is used by certain security organizations.

## IEEE-1344 Bit Definition

Bit Position	Bit Definition	Explanation
P50	Year, BCD1	Unit years
P51	Year, BCD2	
P52	Year, BCD4	
P53	Year, BCD8	
P54	Not used	
P55	Year, BCD10	Tens years
P56	Year, BCD20	
P57	Year, BCD40	
P58	Year, BCD80	
P59	P6	Position identifier
P60	Leap second pending	Set to one, 59 seconds prior to leap insertion
P61	Leap second	0 = add second, 1 = delete second
P62	Daylight Savings Time pending	Set to one, 1 second prior to DST change
P63	Daylight Savings Time	1 = DST active
P64	Local offset sign	0 = +, 1 = -
P65	Local offset binary 1	Local offset from UTC time
P66	Local offset binary 2	
P67	Local offset binary 4	
P68	Local offset binary 8	
P69	P7	Position identifier
P70	Local offset half hour bit	0 = none, 1 = half hour time offset added
P71	Time quality binary 1	Time quality indicates clock precision.*
P72	Time quality binary 2	
P73	Time quality binary 4	
P74	Time quality binary 8	
P75	Parity	Odd parity for all preceding data bits
P76-P78	Not used	
P79	P8	Position identifier

\* Refer to *Appendix A - Time Figure-of-Merit* for detailed information. Briefly:

- 6 time error is < 100 us
- 7 time error is < 1 ms
- 8 time error is < 10 ms
- 9 time error is > 10 ms, unsynchronized state if never locked to CDMA.

# Appendix H

## *Leap Seconds*

*The front-panel display of your Meridian can operate in three different time modes: GPS, UTC and Local. The Network Time Protocol (NTP) always uses UTC for its time mode. Both UTC and Local times are affected by leap seconds. This is an additional second that is inserted into UTC in order to keep it in agreement with the Earth's rotation. Leap seconds may only be inserted at UTC midnight on June 30th or on December 31st. Leap second insertions (or transitions) occur about every 2 years, on average.*

Your Meridian can automatically get the leap second information from the CDMA transmissions. However, some of the CDMA providers have not implemented this to the level of precision needed for a perfectly smooth transition at UTC midnight on the day of a leap second insertion. To ensure that your Meridian will precisely handle any UTC leap second transitions, your unit has been configured at the factory for the user-entered leap mode.

If you prefer to have your Meridian automatically get its leap second information from the CDMA transmissions then just change the leap mode to automatic. You can do this by using console command `cdmaleapconfig` (see *Chapter 4 - Control and Status Commands*). To view the leap second settings use command `cdmaleapmode`. You can also monitor and change the leap second information via the front-panel keypad and display (see *Chapter 3 - Front-Panel Keypad and Display*).

In the user-entered leap mode, the current and future leap second values must be manually set. You can do this by using console command `cdmaleapconfig`. When the unit is configured at the factory, the current and future leap second values are set appropriately for the next possible leap second insertion date (June 30th or December 31st). If there is no leap second insertion scheduled, then the same value is set for both the current and future leap seconds. If there is a leap second insertion scheduled, then a future value is set that is one more than the current value.

For example, as of this writing (July 2005) there are 13 leap seconds. The next possible leap second insertion date is December 31st and there WILL be a leap second insertion on that date. After December 31st there will be 14 leap seconds. So, all units shipped from the factory between July 2005 and the end of December 2005 will have a current leap second value of 13 and a future leap second value of 14. Your Meridian will remember the settings and make a perfect leap second transition at midnight on December 31st. If you happen to have your unit powered off on December 31st, then when power is reapplied, it will know that the leap second transition has passed and behave appropriately. After December 31st, your unit will show that both the current and future leap seconds are 14. This will continue as long as there is no new leap second insertion scheduled, probably for many years. When a new leap second insertion is scheduled you will need to alter the current and future values.

The EndRun Technologies' website has a page devoted to notifying users of the next leap second occurrence. It also posts the appropriate current and future leap seconds setting for your Meridian. The appropriate link is: <http://www.endruntechnologies.com/leap.htm>

## **Background Information**

Another way to get the leap second information is to go to the International Earth Rotation Service (IERS) website. If a leap second is pending it will be posted by the IERS approximately six months in advance of insertion. This information is available in the latest Bulletin C at the (IERS) website:

<http://www.iers.org>

Leap seconds are inserted from time-to-time in order to keep UTC, which is derived from atomic time (TAI), in agreement with the Earth's rotation rate. Relative to TAI, the Earth's rotation rate is slowing down. This means that UTC must be retarded periodically in order to maintain agreement between UTC and the apparent daylength. If this were not done, eventually UTC would drift out-of-sync with Earth's day and many astronomical and navigational problems would ensue.

The International Earth Rotation Service (IERS) is the organization responsible for measuring the relationship between UTC and the rotation rate of the Earth. When the difference between UTC and apparent Earth time has exceeded a certain threshold, the IERS coordinates with the Bureau International of the Hour (BIH) to schedule the insertion of a leap second into the UTC time scale.

The IERS publishes Bulletin C about 6 months in advance of each possible leap second insertion point. Leap seconds may only be inserted at UTC midnight of June 30 or December 31. Bulletin C confirms either that a leap second will or will not be inserted at the next possible insertion point. Since the introduction of leap seconds in 1961, they have been added approximately once every 18 months.

The leap seconds which are needed for your Meridian are actually the difference between GPS-UTC. The GPS time scale began on January 6, 1980. At that time, the UTC timescale had already undergone 19 leapsecond insertion events. If you are obtaining your leap second information from the IERS website, you will need to subtract 19 from the TAI-UTC leap second values published there to obtain GPS-UTC, the number needed to set the current and future leap seconds for the Meridian. At the time of this writing in July of 2005, TAI-UTC was 32 seconds and GPS-UTC was 13 seconds.

# Appendix I

## IPv6 Information

EndRun Technologies understands that IPv6 is still in the experimental stage with essentially no mainstream deployment. Customers who are not interested in IPv6 need not burden your system with it. You have a choice of an IPv4-only kernel (recommended) or the IPv4/IPv6-kernel. You may freely change this at any time with an easy software download from our website.

To determine which kernel resides in your Meridian check the firmware version using the front-panel keypad/display. Or you can use the console port command `cat /proc/version`.

An IPv4-only kernel will have a part number and version similar to:

6010-0041-000 ver 2.4.31-IPv4

An IPv4/IPv6 kernel will have a part number and version similar to:

6010-0041-100 ver 2.4.31-IPv6

If you want to change your kernel please refer to *Appendix B - Upgrading The Firmware* for instructions. The following text refers to products with the IPv4/IPv6 kernel.

### Enabling New IPv6 Capabilities

The presence of an IPv6-capable kernel will automatically enable most of the new IPv6 capabilities. By default, autoconfiguration of the ethernet interface via IPv6 Router Advertisements is enabled. To disable acceptance of Router Advertisements, or to configure a static IPv6 address and default IPv6 gateway, you must either run the interactive `netconfig` script or use the front-panel keypad/display. Either method will allow you to configure your ethernet interface for both IPv4 and IPv6 operation. Using the `netconfig` script has the advantage that you can also configure the hostname and domain name for the unit, and any nameservers you may want it to have access to.

#### OpenSSH

By default, `sshd` is factory-configured to listen on both IPv4 and IPv6 addresses. It may be forced to listen on either IPv4 only, or IPv6 only by editing the `/etc/rc.d/rc.inet2` startup script, where `sshd` is started, and then copying it to `/boot/etc/rc.d`.

#### Net-SNMP

By default, `snmpd` is factory configured to listen on both IPv4 and IPv6 addresses. This may be changed by editing `/etc/rc.d/rc.local` and modifying the agent address argument passed to `snmpd` at start-up, and then copying it to `/boot/etc/rc.d`.

**IPv6-Capable syslog-ng**

To enable remote syslogging to an IPv6 host, you will need to edit the new */etc/syslog-ng.conf* file and copy it to */boot/etc*. At boot time, the presence of both the **syslog-ng** daemon and the *boot/etc/syslog-ng.conf* file will cause the new IPv6-capable **syslog-ng** daemon to be started instead of the previous **syslogd/klogd** pair of daemons. These two files remain on the system for backward compatibility with customers' existing */etc/syslog.conf* setups, but they are not IPv6 capable. If you are not currently directing your system logs to a remote host, or you are not using IPv6, then there is little or need or benefit to changing to **syslog-ng**.

**IPv4-Only Protocols**

There are several protocols which are not IPv6 capable: **telnet** (client and server), **http**, **ftp** and **dhcpcd**. Due to their intrinsic insecurity, **telnet** and **ftp** are rapidly being deprecated, and probably have little business running over an IPv6 network. The address autoconfiguration capabilities of IPv6 make the DHCP protocol less important, however it is likely that the new **dhcpcv6** capability will appear in a future upgrade.

# Appendix J

## *Third-Party Software*

*The Meridian is running several different software products created and/or maintained by open source projects. Open source software comes with its own license. These are printed out for your information below.*

The license for the GNU software project requires that we provide you with a copy of all source code covered under the GNU Public License (GPL) at your request. Please contact us with your request and we will mail it to you on a CD. We will charge you a fee for our incurred expenses as allowed for in the license.

### **GNU General Public License**

GNU GENERAL PUBLIC LICENSE

Version 2, June 1991

Copyright (C) 1989,1991 Free Software Foundation, Inc.,

51 Franklin Street, Fifth Floor, Boston, MA 02110-1301 USA

Everyone is permitted to copy and distribute verbatim copies of this license document, but changing it is not allowed.

#### Preamble

The licenses for most software are designed to take away your freedom to share and change it. By contrast, the GNU General Public License is intended to guarantee your freedom to share and change free software--to make sure the software is free for all its users. This General Public License applies to most of the Free Software Foundation's software and to any other program whose authors commit to using it. (Some other Free Software Foundation software is covered by the GNU Lesser General Public License instead.) You can apply it to your programs, too.

When we speak of free software, we are referring to freedom, not price. Our General Public Licenses are designed to make sure that you have the freedom to distribute copies of free software (and charge for this service if you wish), that you receive source code or can get it if you want it, that you can change the software or use pieces of it in new free programs; and that you know you can do these things.

To protect your rights, we need to make restrictions that forbid anyone to deny you these rights or to ask you to surrender the rights. These restrictions translate to certain responsibilities for you if you distribute copies of the software, or if you modify it.

For example, if you distribute copies of such a program, whether gratis or for a fee, you must give the

recipients all the rights that you have. You must make sure that they, too, receive or can get the source code. And you must show them these terms so they know their rights.

We protect your rights with two steps: (1) copyright the software, and (2) offer you this license which gives you legal permission to copy, distribute and/or modify the software.

Also, for each author's protection and ours, we want to make certain that everyone understands that there is no warranty for this free software. If the software is modified by someone else and passed on, we want its recipients to know that what they have is not the original, so that any problems introduced by others will not reflect on the original authors' reputations.

Finally, any free program is threatened constantly by software patents. We wish to avoid the danger that redistributors of a free program will individually obtain patent licenses, in effect making the program proprietary. To prevent this, we have made it clear that any patent must be licensed for everyone's free use or not licensed at all.

The precise terms and conditions for copying, distribution and modification follow.

#### GNU GENERAL PUBLIC LICENSE TERMS AND CONDITIONS FOR COPYING, DISTRIBUTION AND MODIFICATION

0. This License applies to any program or other work which contains a notice placed by the copyright holder saying it may be distributed under the terms of this General Public License. The "Program", below, refers to any such program or work, and a "work based on the Program" means either the Program or any derivative work under copyright law: that is to say, a work containing the Program or a portion of it, either verbatim or with modifications and/or translated into another language. (Hereinafter, translation is included without limitation in the term "modification".) Each licensee is addressed as "you".

Activities other than copying, distribution and modification are not covered by this License; they are outside its scope. The act of running the Program is not restricted, and the output from the Program is covered only if its contents constitute a work based on the Program (independent of having been made by running the Program). Whether that is true depends on what the Program does.

1. You may copy and distribute verbatim copies of the Program's source code as you receive it, in any medium, provided that you conspicuously and appropriately publish on each copy an appropriate copyright notice and disclaimer of warranty; keep intact all the notices that refer to this License and to the absence of any warranty; and give any other recipients of the Program a copy of this License along with the Program.

You may charge a fee for the physical act of transferring a copy, and you may at your option offer warranty protection in exchange for a fee.

2. You may modify your copy or copies of the Program or any portion of it, thus forming a work based on the Program, and copy and distribute such modifications or work under the terms of Section 1 above, provided that you also meet all of these conditions:

a) You must cause the modified files to carry prominent notices stating that you changed the files and the date of any change.



b) You must cause any work that you distribute or publish, that in whole or in part contains or is derived from the Program or any part thereof, to be licensed as a whole at no charge to all third parties under the terms of this License.

c) If the modified program normally reads commands interactively when run, you must cause it, when started running for such interactive use in the most ordinary way, to print or display an announcement including an appropriate copyright notice and a notice that there is no warranty (or else, saying that you provide a warranty) and that users may redistribute the program under these conditions, and telling the user how to view a copy of this License. (Exception: if the Program itself is interactive but does not normally print such an announcement, your work based on the Program is not required to print an announcement.)

These requirements apply to the modified work as a whole. If identifiable sections of that work are not derived from the Program, and can be reasonably considered independent and separate works in themselves, then this License, and its terms, do not apply to those sections when you distribute them as separate works. But when you distribute the same sections as part of a whole which is a work based on the Program, the distribution of the whole must be on the terms of this License, whose permissions for other licensees extend to the entire whole, and thus to each and every part regardless of who wrote it.

Thus, it is not the intent of this section to claim rights or contest your rights to work written entirely by you; rather, the intent is to exercise the right to control the distribution of derivative or collective works based on the Program.

In addition, mere aggregation of another work not based on the Program with the Program (or with a work based on the Program) on a volume of a storage or distribution medium does not bring the other work under the scope of this License.

3. You may copy and distribute the Program (or a work based on it, under Section 2) in object code or executable form under the terms of Sections 1 and 2 above provided that you also do one of the following:

a) Accompany it with the complete corresponding machine-readable source code, which must be distributed under the terms of Sections 1 and 2 above on a medium customarily used for software interchange; or,

b) Accompany it with a written offer, valid for at least three years, to give any third party, for a charge no more than your cost of physically performing source distribution, a complete machine-readable copy of the corresponding source code, to be distributed under the terms of Sections 1 and 2 above on a medium customarily used for software interchange; or,

c) Accompany it with the information you received as to the offer to distribute corresponding source code. (This alternative is allowed only for noncommercial distribution and only if you received the program in object code or executable form with such an offer, in accord with Subsection b above.)

The source code for a work means the preferred form of the work for making modifications to it. For an executable work, complete source code means all the source code for all modules it contains, plus any associated interface definition files, plus the scripts used to control compilation and installation of

the executable. However, as a special exception, the source code distributed need not include anything that is normally distributed (in either source or binary form) with the major components (compiler, kernel, and so on) of the operating system on which the executable runs, unless that component itself accompanies the executable.

If distribution of executable or object code is made by offering access to copy from a designated place, then offering equivalent access to copy the source code from the same place counts as distribution of the source code, even though third parties are not compelled to copy the source along with the object code.

4. You may not copy, modify, sublicense, or distribute the Program except as expressly provided under this License. Any attempt otherwise to copy, modify, sublicense or distribute the Program is void, and will automatically terminate your rights under this License. However, parties who have received copies, or rights, from you under this License will not have their licenses terminated so long as such parties remain in full compliance.

5. You are not required to accept this License, since you have not signed it. However, nothing else grants you permission to modify or distribute the Program or its derivative works. These actions are prohibited by law if you do not accept this License. Therefore, by modifying or distributing the Program (or any work based on the Program), you indicate your acceptance of this License to do so, and all its terms and conditions for copying, distributing or modifying the Program or works based on it.

6. Each time you redistribute the Program (or any work based on the Program), the recipient automatically receives a license from the original licensor to copy, distribute or modify the Program subject to these terms and conditions. You may not impose any further restrictions on the recipients' exercise of the rights granted herein. You are not responsible for enforcing compliance by third parties to this License.

7. If, as a consequence of a court judgment or allegation of patent infringement or for any other reason (not limited to patent issues), conditions are imposed on you (whether by court order, agreement or otherwise) that contradict the conditions of this License, they do not excuse you from the conditions of this License. If you cannot distribute so as to satisfy simultaneously your obligations under this License and any other pertinent obligations, then as a consequence you may not distribute the Program at all. For example, if a patent license would not permit royalty-free redistribution of the Program by all those who receive copies directly or indirectly through you, then the only way you could satisfy both it and this License would be to refrain entirely from distribution of the Program.

If any portion of this section is held invalid or unenforceable under any particular circumstance, the balance of the section is intended to apply and the section as a whole is intended to apply in other circumstances.

It is not the purpose of this section to induce you to infringe any patents or other property right claims or to contest validity of any such claims; this section has the sole purpose of protecting the integrity of the free software distribution system, which is implemented by public license practices. Many people have made generous contributions to the wide range of software distributed through that system in reliance on consistent application of that system; it is up to the author/donor to decide if he or she is willing to distribute software through any other system and a licensee cannot impose that choice.

This section is intended to make thoroughly clear what is believed to be a consequence of the rest of this License.

---

## THIRD-PARTY SOFTWARE

8. If the distribution and/or use of the Program is restricted in certain countries either by patents or by copyrighted interfaces, the original copyright holder who places the Program under this License may add an explicit geographical distribution limitation excluding those countries, so that distribution is permitted only in or among countries not thus excluded. In such case, this License incorporates the limitation as if written in the body of this License.

9. The Free Software Foundation may publish revised and/or new versions of the General Public License from time to time. Such new versions will be similar in spirit to the present version, but may differ in detail to address new problems or concerns.

Each version is given a distinguishing version number. If the Program specifies a version number of this License which applies to it and “any later version”, you have the option of following the terms and conditions either of that version or of any later version published by the Free Software Foundation. If the Program does not specify a version number of this License, you may choose any version ever published by the Free Software Foundation.

10. If you wish to incorporate parts of the Program into other free programs whose distribution conditions are different, write to the author to ask for permission. For software which is copyrighted by the Free Software Foundation, write to the Free Software Foundation; we sometimes make exceptions for this. Our decision will be guided by the two goals of preserving the free status of all derivatives of our free software and of promoting the sharing and reuse of software generally.

### NO WARRANTY

11. BECAUSE THE PROGRAM IS LICENSED FREE OF CHARGE, THERE IS NO WARRANTY FOR THE PROGRAM, TO THE EXTENT PERMITTED BY APPLICABLE LAW. EXCEPT WHEN OTHERWISE STATED IN WRITING THE COPYRIGHT HOLDERS AND/OR OTHER PARTIES PROVIDE THE PROGRAM “AS IS” WITHOUT WARRANTY OF ANY KIND, EITHER EXPRESSED OR IMPLIED, INCLUDING, BUT NOT LIMITED TO, THE IMPLIED WARRANTIES OF MERCHANTABILITY AND FITNESS FOR A PARTICULAR PURPOSE. THE ENTIRE RISK AS TO THE QUALITY AND PERFORMANCE OF THE PROGRAM IS WITH YOU. SHOULD THE PROGRAM PROVE DEFECTIVE, YOU ASSUME THE COST OF ALL NECESSARY SERVICING, REPAIR OR CORRECTION.

12. IN NO EVENT UNLESS REQUIRED BY APPLICABLE LAW OR AGREED TO IN WRITING WILL ANY COPYRIGHT HOLDER, OR ANY OTHER PARTY WHO MAY MODIFY AND/OR REDISTRIBUTE THE PROGRAM AS PERMITTED ABOVE, BE LIABLE TO YOU FOR DAMAGES, INCLUDING ANY GENERAL, SPECIAL, INCIDENTAL OR CONSEQUENTIAL DAMAGES ARISING OUT OF THE USE OR INABILITY TO USE THE PROGRAM (INCLUDING BUT NOT LIMITED TO LOSS OF DATA OR DATA BEING RENDERED INACCURATE OR LOSSES SUSTAINED BY YOU OR THIRD PARTIES OR A FAILURE OF THE PROGRAM TO OPERATE WITH ANY OTHER PROGRAMS), EVEN IF SUCH HOLDER OR OTHER PARTY HAS BEEN ADVISED OF THE POSSIBILITY OF SUCH DAMAGES.

END OF TERMS AND CONDITIONS

## NTP Software License

Information about the NTP Project, led by Dr. David Mills, can be found at [www.ntp.org](http://www.ntp.org). The distribution and usage of the NTP software is allowed, as long as the following copyright notice is included in our documentation:

The following copyright notice applies to all files collectively called the Network Time Protocol Version 4 Distribution. Unless specifically declared otherwise in an individual file, this notice applies as if the text was explicitly included in the file.

```
*****
*
* Copyright (c) David L. Mills 1992-2006
*
* Permission to use, copy, modify, and distribute this software and
* its documentation for any purpose with or without fee is hereby
* granted, provided that the above copyright notice appears in all
* copies and that both the copyright notice and this permission
* notice appear in supporting documentation, and that the name
* University of Delaware not be used in advertising or publicity
* pertaining to distribution of the software without specific,
* written prior permission. The University of Delaware makes no
* representations about the suitability this software for any
* purpose. It is provided "as is" without express or implied
* warranty.
*
*****
```

## Apache Software License

The Apache server as implemented in the Meridian is cover by copyrights.

See the license at <http://www.apache.org/licenses/LICENSE-1.1>

Information about Apache can be found at <http://httpd.apache.org>. The distribution and usage of Apache is allowed, as long as the following copyright notice is included in our documentation. This notice applies as if the text was explicitly included each file.

```
/* =====
* The Apache Software License, Version 1.1
*
* Copyright (c) 2000 The Apache Software Foundation. All rights
* reserved.
*
* Redistribution and use in source and binary forms, with or without
* modification, are permitted provided that the following conditions
* are met:
*
* 1. Redistributions of source code must retain the above copyright
* notice, this list of conditions and the following disclaimer.
*
* =====
```

---

## THIRD-PARTY SOFTWARE

\* 2. Redistributions in binary form must reproduce the above copyright  
\* notice, this list of conditions and the following disclaimer in  
\* the documentation and/or other materials provided with the  
\* distribution.

\*  
\* 3. The end-user documentation included with the redistribution,  
\* if any, must include the following acknowledgment:  
\* "This product includes software developed by the  
\* Apache Software Foundation (<http://www.apache.org/>)."  
\* Alternately, this acknowledgment may appear in the software itself,  
\* if and wherever such third-party acknowledgments normally appear.

\*  
\* 4. The names "Apache" and "Apache Software Foundation" must  
\* not be used to endorse or promote products derived from this  
\* software without prior written permission. For written  
\* permission, please contact [apache@apache.org](mailto:apache@apache.org).

\*  
\* 5. Products derived from this software may not be called "Apache",  
\* nor may "Apache" appear in their name, without prior written  
\* permission of the Apache Software Foundation.

\* THIS SOFTWARE IS PROVIDED ``AS IS'' AND ANY EXPRESSED OR IMPLIED  
\* WARRANTIES, INCLUDING, BUT NOT LIMITED TO, THE IMPLIED WARRANTIES  
\* OF MERCHANTABILITY AND FITNESS FOR A PARTICULAR PURPOSE ARE  
\* DISCLAIMED. IN NO EVENT SHALL THE APACHE SOFTWARE FOUNDATION OR  
\* ITS CONTRIBUTORS BE LIABLE FOR ANY DIRECT, INDIRECT, INCIDENTAL,  
\* SPECIAL, EXEMPLARY, OR CONSEQUENTIAL DAMAGES (INCLUDING, BUT NOT  
\* LIMITED TO, PROCUREMENT OF SUBSTITUTE GOODS OR SERVICES; LOSS OF  
\* USE, DATA, OR PROFITS; OR BUSINESS INTERRUPTION) HOWEVER CAUSED AND  
\* ON ANY THEORY OF LIABILITY, WHETHER IN CONTRACT, STRICT LIABILITY,  
\* OR TORT (INCLUDING NEGLIGENCE OR OTHERWISE) ARISING IN ANY WAY OUT  
\* OF THE USE OF THIS SOFTWARE, EVEN IF ADVISED OF THE POSSIBILITY OF  
\* SUCH DAMAGE.

\* =====  
\*

\* This software consists of voluntary contributions made by many  
\* individuals on behalf of the Apache Software Foundation. For more  
\* information on the Apache Software Foundation, please see  
\* <http://www.apache.org/>.

\*  
\* Portions of this software are based upon public domain software  
\* originally written at the National Center for Supercomputing Applications,  
\* University of Illinois, Urbana-Champaign.  
\*/

## PTP Software License

The PTP/IEEE-1588 option as implemented in the Meridian is covered by patents and copyrights.

See the IEEE Standards Association at: <http://standards.ieee.org/db/patents/pat1390.html> for patents that pertain the the Std No 1588.

Information about the PTP Project, led by Kendall Correll, can be found at [ptpd.sourceforge.net](http://ptpd.sourceforge.net) The distribution and usage of the PTP software is allowed, as long as the following copyright notice is included in our documentation.

The following copyright notice applies to all files which compose the PTPd. This notice applies as if the text was explicitly included each file.

Copyright (c) 2005-2008 Kendall Correll, Aidan Williams

Permission to use, copy, modify, and/or distribute this software for any purpose with or without fee is hereby granted, provided that the above copyright notice and this permission notice appear in all copies.

THE SOFTWARE IS PROVIDED "AS IS" AND THE AUTHOR DISCLAIMS ALL WARRANTIES WITH REGARD TO THIS SOFTWARE INCLUDING ALL IMPLIED WARRANTIES OF MERCHANTABILITY AND FITNESS. IN NO EVENT SHALL THE AUTHOR BE LIABLE FOR ANY SPECIAL, DIRECT, INDIRECT, OR CONSEQUENTIAL DAMAGES OR ANY DAMAGES WHATSOEVER RESULTING FROM LOSS OF USE, DATA OR PROFITS, WHETHER IN AN ACTION OF CONTRACT, NEGLIGENCE OR OTHER TORTIOUS ACTION, ARISING OUT OF OR IN CONNECTION WITH THE USE OR PERFORMANCE OF THIS SOFTWARE.

# Appendix K

## Precision Time Protocol (PTP) IEEE-1588

*This appendix contains the configuration and status information for the optional Precision Time Protocol. Both PTP version 1 and PTP version 2 are available. The PTPv2 protocol running on the Meridian is a full Grandmaster Clock (default profile) implementation of the IEEE-1588-2008 standard. The PTPv1 protocol is a full Grandmaster Clock implementation of the IEEE-1588 2002 standard. The PTP version is user-selectable and once configured, the Meridian operates as a PTP Grandmaster Version 1 OR Version 2.*

### About PTP

The PTP implementation in the Meridian is built from the distribution at the PTPd website:  
<http://ptpd.sourceforge.net>.

The PTP daemon status and configuration is supported from two PTP companion utilities **cptpstat** or **cptpstat** and **ptpconfig** or **ptp2config**. The following table shows the Meridian utilities that pertain to PTPv1 and PTPv2:

	Daemon	Status	Configuration
PTPv1	<b>ptpd</b>	<b>cptpstat</b>	<b>ptpconfig</b>
PTPv2	<b>ptp2d</b>	<b>cptp2stat</b>	<b>ptp2config</b>

For more information about **ptpd** and to obtain PTP Slave software, refer to the PTPd website. When downloading PTP Slave software from the PTPd website, be sure to obtain this version: *ptpd-1.00.tar.gz* if using PTPv1 or *ptpd-2.1.0.tar.gz* if using PTPv2.

An excellent book which describes the PTP Master and Slave operation is:

*Measurement, Control, and Communication using IEEE 1588,*  
John C. Eidson, Springer, November 2006.

More information on IEEE-1588 PTP can be found at the NIST National Institute of Standards and Technology IEEE 1588 website: <http://ieee1588.nist.gov>.

## Version PTPv2 or PTPv1

In the Meridian, you may use the PTPv1 protocol or the PTPv2 protocol. PTPv2 is the default. In order to change the selection from PTPv2 to PTPv1 you can use either the keypad/display or the serial/network port.

### Changing PTP Version Using the Keypad/Display

If your unit has the optional PTP capability then there will be an item in the list of Main Menu selections called: “PTP”. Press the RIGHT/LEFT arrow key until this is highlighted and press ENTER to select it. Then press the RIGHT/LEFT arrow keys to highlight “Version” and press ENTER.

Press EDIT to change the PTP version from version 2 to version 1 and vice-versa. Press the HELP key at any time to view the context-sensitive help information. When you are finished the unit will reset.

### Changing PTP Version Using the Network or Serial Port

The `ptpversionconfig` command starts an interactive shell script that will allow you to change the PTP version. The following is a transcript of the question and answer configuration utility provided by `ptpversionconfig`.

```
Meridian CDMA(root@endrun:~)-> ptpversionconfig

*****
*****Precision Time Protocol IEEE-1588 Version Configuration*****
*****
*
*   This script will allow you to configure PTP Version 1 or 2
*
*
*   The changes you make now will not take effect until you re-boot the
*   Meridian CDMA. If you make a mistake, just re-run ptpversionconfig prior
*   to re-booting.
*
*   You will now be prompted for the necessary set up parameters.
*
*****
---PTP Version Configuration

Set the PTP Version (1 or 2) 2

Configuring PTP to start as Version 2...

*****
*****
*
*   The Meridian CDMA Precision Time Protocol IEEE-1588 Version configuration
*   has been updated.
*
*           Please re-boot now for the changes to take effect.
*
*****
*****
```



Now reboot the system by issuing this command at the shell prompt:

```
shutdown -r now
```

## PTPv2 Configuration and Status

The default PTPv2 configuration settings in the Meridian are shown below. If you need to modify these settings then you will need to reconfigure the PTPv2 subsystem. You may perform the configuration from either a **telnet** or **ssh** session, or the local RS-232 console. Default PTPv2 settings are:

Sync Interval:	1 second
Announce Interval:	16 seconds
Priority 1:	127
Priority 2:	128
Delay Mechanism:	P2P
Domain:	0
PTP Time Mode:	UTC
PTP TTL:	1

### PTPv2 Configuration and Status Using the Keypad/Display

If your unit has the optional PTP capability then there will be an item in the list of Main Menu selections called: “PTP”. Press the RIGHT/LEFT arrow key until this is highlighted and press ENTER to select it. Then press the RIGHT/LEFT arrow keys to highlight “Status” or “Setup” and press ENTER.

The “Status” selection will let you see the current status of the PTP subsystem.

For the “Setup” selection, press EDIT to reconfigure PTP. The sequence of edit displays will guide you through the setup process. Press the HELP key at any time to view the context-sensitive help information. When you are finished the unit will reset.

### PTPv2 Configuration Using the Network or Serial Port

The **ptp2config** command starts an interactive shell script that will allow you to configure the PTPv2 subsystem of the Meridian. You will be prompted to set PTPv2 parameters as follows:

Sync Interval:	1 or 2
Announce Interval:	1, 2, 3, 8, or 16
Priority1:	0-255
Priority2:	0-255
Delay Mechanism:	E2E or P2P
Domain:	0-255
PTP Time Mode:	UTC or PTP
PTP TTL:	1-255

---

## APPENDIX K

One file is modified, */etc/ptp2.conf*. This is a non-volatile stored file in the FLASH disk */boot/etc* directory. You must reboot the Meridian after running this script for the changes to take effect.

The following is a transcript of the question and answer configuration utility provided by *ptp2config*. The user-entered parameters are underlined:

Meridian CDMA(root@csys)-> ptp2config

```
*****
*****Precision Time Protocol IEEE-1588 V2 Configuration*****
*****
*
*   This script will allow you to configure the ptp2.conf file
*   that controls the PTP V2 daemon operation.
*
*   You will be able to configure the PTP sync interval, announce interval,
*   priority1, priority2, delay mechanism , ptp domain, time mode, and ttl.
*
*   The changes you make now will not take effect until you re-boot the
*   Meridian CDMA. If you make a mistake, just re-run ptp2config prior to
*   re-booting.
*
*   You will now be prompted for the necessary set up parameters.
*****
*****

---PTP Sync Interval Configuration

Set the PTP Sync Interval in seconds (1 or 2) 1

---PTP announce interval Configuration

Set the PTP Announce Interval in seconds (1, 2, 4, 8, 16) 16

---PTP Priority1 Configuration

Set the PTP Priority1 value (0-255) 127

---PTP Priority2 Configuration

Set the PTP Priority2 value (0-255) 128

---PTP Delay Mechanism E2E or P2P

Set the PTP Delay Mechanism (E2E or P2P) P2P

---PTP Domain Configuration

Set the PTP Domain value (0-255) 0

---PTP Time Mode Configuration

Set the PTP Time Mode (UTC or PTP) UTC

---PTP TTL Configuration

Set the PTP TTL value (1-255) 1
```

```

*****
*****
*
* The Meridian CDMA Precision Time Protocol IEEE-1588 V2 configuration has *
* been updated. *
* *
* Please re-boot now for the changes to take effect. *
* *
*****
*****
*****

```

Now reboot the system by issuing this command at the shell prompt:

```
shutdown -r now
```

### PTPv2 Status Using the Network or Serial Port

The `cptp2stat` command allows you to query the status of the PTPv2 subsystem. The `ptp2d` daemon running on the system updates the `/var/log/ptp.monitor` every five seconds under normal operation. This logfile is parsed and formatted to provide the status string having these fields:

```
V SI AI P1 P2 DM DOM MODE TTL CLASS SCALE STATE CLKID UTC UTCV
CA L59 L61 TT FT
```

Where:

- V is the IEEE-1588 version 2 for the 2008 standard.
- SI is the PTP sync interval, either 1 or 2 seconds.
- AI is the PTP announce interval, either 1, 2, 4, 8, or 16 seconds.
- P1 is the PTP priority 1 in a range from 0 to 255.
- P2 is the PTP priority 2 in a range from 0 to 255.
- DM is the PTP delay mechanism , either E2E or P2P.
- DOM is the PTP domain, in a range from 0 to 255.
- MODE is the PTP time mode, either UTC or PTP.
- TTL is the PTP multicast ttl in a range from 1 to 255.
- CLASS is the PTP clock class either SYNCHRONIZED, HOLDOVER, or UNLOCKED.
- SCALE is the PTP timescale either PTP or ARB.
- STATE is the PTP port state either MASTER, PASSIVE, or LISTENING.
- CLKID is the PTP clock source either GPS, or OSC.
- UTC is the PTP utc offset in seconds.

UTCv	is the PTP utc offset valid, either TRUE or FALSE.
CA	is the PTP clock accuracy either 1us, 2.5us, 10us, 25us, 100us, 250us, 1ms, 2.5ms, 10ms, or Unknown.
L59	is the PTP leap 59 second indicator, either TRUE or FALSE.
L61	is the PTP leap 61 second indicator, either TRUE or FALSE.
TT	is the PTP time traceable indicator, either TRUE or FALSE.
FT	is the PTP frequency traceable indicator, either TRUE or FALSE.

## **PTPv2 Operation**

The Meridian is configured as an IEEE-1588 Grandmaster Clock (default profile). Verify that the network settings have been configured and tested using **netconfig**. Once the network has been configured the Meridian will begin to transmit PTP Sync messages after it is locked.

The PTP Sync Interval is user configured, either 1 or 2 seconds is transmitted as a multicast. The packet is only transmitted when the clock is fully synchronized or in holdover. The delay interval is 2 seconds.

The PTP Announce Interval is user configured, either 1, 2, 4, 8, or 16 seconds is transmitted as a multicast. The packet is only transmitted when the clock is fully synchronized or in holdover. The Announce Interval must be no shorter than the Sync Interval.

The PTP Priority 1 is user configured in a range from 0 to 255.

The PTP Priority 2 is user configured in a range from 0 to 255.

The PTP Delay Mechanism is user configured either E2E or P2P. E2E uses the delay request-response mechanism. P2P uses the peer delay mechanism.

The PTP Domain is user configured in a range from 0 to 255.

The PTP Time Mode is user configured, either UTC or PTP. When UTC Time mode is configured the clock transmits the UTC epoch and sets the PTP Scale to ARB. When the Time mode is PTP the clock transmits the PTP epoch (TAI) and sets the PTP Scale to PTP. See ***About the PTP Second and UTC Time*** at the end of this appendix for more information.

The PTP Multicast TTL is user configured in a range from 1 to 255. For a local area network the TTL is configured to 1.

PTP Clock Class either SYNCHRONIZED, HOLDOVER, or UNLOCKED. The Clock Class is SYNCHRONIZED when the TFOM level is at 6. The Clock Class is HOLDOVER when the TFOM level is greater than 6 and less than 9. The Clock Class is UNLOCKED when the TFOM level is 9.

The PTP Timescale either PTP or ARB. When Time Mode is configured to PTP the clock transmits the Timescale as PTP. When the Time mode is UTC the clock transmits the Timescale as ARB.

The PTP Port State either MASTER, PASSIVE, or LISTENING. The PTP Port State is selected as MASTER by the best master clock algorithm, otherwise it is PASSIVE or LISTENING.

The PTP Clock Source either GPS, or OSC. The PTP Clock Source is GPS if the Clock Class is Synchronized, otherwise it is OSC based on the internal oscillator.

The PTP UTC Offset. The PTP UTC Offset is the offset between TAI and UTC in units of seconds.

The PTP UTC Offset Valid either TRUE or FALSE. The PTP UTC Offset Valid is TRUE if the current PTP UTC Offset is known to be correct, otherwise it is FALSE.

The PTP Clock Accuracy is transmitted when the time is accurate to within the the following:

1us	Clock is synchronized or in holdover, PTP clock < 1 microsecond
2.5us	Clock is synchronized or in holdover, PTP clock < 2.5 microseconds
10us	Clock is synchronized or in holdover, PTP clock < 10 microseconds
25us	Clock is synchronized or in holdover, PTP clock < 25 microseconds
100us	Clock is synchronized or in holdover, PTP clock < 100 microseconds
250us	Clock is synchronized or in holdover, PTP clock < 250 microseconds
1ms	Clock is synchronized or in holdover, PTP clock < 1 millisecond
2.5ms	Clock is synchronized or in holdover, PTP clock < 2.5 milliseconds
10ms	Clock is synchronized or in holdover, PTP clock < 10 milliseconds
Unknown	Clock is unsynchronized, TFOM = 9

The PTP Leap 59 second indicator, either TRUE or FALSE. The Leap 59 is TRUE if the PTP Timescale is PTP and the last minute of the current UTC day contains 59 seconds, otherwise it is FALSE.

The PTP Leap 61 second indicator, either TRUE or FALSE. The Leap 61 is TRUE if the PTP Timescale is PTP and the last minute of the current UTC day contains 61 seconds, otherwise it is FALSE.

The PTP Time Traceable indicator, either TRUE or FALSE. The Time Traceable is TRUE if the Time Scale is PTP and the Clock Class is Synchronized or Holdover, otherwise it is FALSE.

The PTP Frequency Traceable indicator, either TRUE or FALSE. The Frequency Traceable is TRUE if the Time Traceable is TRUE, otherwise it is FALSE.

## PTPv1 Configuration and Status

The default PTPv1 configuration settings in the Meridian are shown below. If you need to modify these settings then you will need to reconfigure the PTPv1 subsystem. You may perform the configuration from either a **telnet** or **ssh** session, or the local RS-232 console. Default PTPv1 settings are:

PTP Preferred:	TRUE
PTP Sync Interval:	Two seconds
PTP Subdomain Name:	DFLT
PTP Time Mode	UTC
PTP TTL	1

### PTPv1 Configuration and Status Using the Keypad/Display

If your unit has the optional PTP capability then there will be an item in the list of Main Menu selections called: “PTP”. Press the RIGHT/LEFT arrow key until this is highlighted and press ENTER to select it. Then press the RIGHT/LEFT arrow keys to highlight “Setup” or “Status” and press ENTER.

The “Status” selection will let you see the current status of the PTP subsystem.

For the “Setup” selection, press EDIT to reconfigure PTP. The sequence of edit displays will guide you through the setup process. Press the HELP key at any time to view the context-sensitive help information. When you are finished the unit will reset.

### PTPv1 Configuration Using the Network or Serial Port

The **ptpconfig** command starts an interactive shell script that will allow you to configure the PTPv1 subsystem of the Meridian. You will be prompted to set the PTPv1 parameters as follows:

Preferred State:	TRUE or FALSE
Sync Interval:	1,2,8,16, or 64 seconds
Subdomain Name:	DFLT, ALT1, ALT2, or ALT3
PTP Time Mode:	UTC or PTP
PTP TTL:	1-255

One file is modified, */etc/ptp.conf*. This is a non-volatile stored file in the FLASH disk */boot/etc* directory. You must reboot the Meridian after running this script for the changes to take effect.

The following is a transcript of the question and answer configuration utility provided by **ptpconfig**. The user entered parameters are underlined:

```
Meridian CDMA(root@csys)-> ptpconfig
```

```

*****
***** Precision Time Protocol Configuration *****
*****
*
*   This script will allow you to configure the ptp.conf file
*   that controls the PTP daemon operation.
*
*   You will be able to configure the PTP sync_interval, preferred state,
*   subdomain_name, and time_mode.
*
*   The changes you make now will not take effect until you re-boot the
*   Meridian . If you make a mistake, just re-run ptpconfig prior to
*   re-booting.
*
*   You will now be prompted for the necessary set up parameters.
*
*****

---PTP preferred Configuration

Set PTP preferred (TRUE, FALSE) TRUE

---PTP sync_interval Configuration

Set the PTP sync_interval in seconds (1,2,8,16,64) 2

---PTP subdomain_name Configuration

Set the PTP subdomain_name (DFLT, ALT1, ALT2, ALT3) DFLT

---PTP time_mode configuration

Set the PTP time_mode (UTC or PTP) PTP

---PTP ttl Configuration

Set the PTP ttl value (1-255) 1

*****
*
*   The Meridian Precision Time Protocol IEEE-1588 configuration has
*   been updated.
*
*   Please re-boot now for the changes to take effect.
*
*****

```

Now reboot the system by issuing this command at the shell prompt:

```
shutdown -r now
```

### PTPv1 Status Using the Network or Serial Port

The `cpstat` command allows the user to query the status of the PTPv1 subsystem. The `ptpd` daemon running on the system updates the `/var/log/ptp.monitor` every five seconds under normal operation. This logfile is parsed and formatted to provide the status string having these fields:

**PTPMODE CKID Stratum SSS PPPPP SDOM II LL TMD V TTL**

Where:

PTPMODE	is the PTP port state, either Master or Passive.
CKID	is the sync identifier, either ATOM or GPS.
SSS	is the PTP stratum, either 3 or 255, where 3 implies an error of > 100 nS and 255 is the unsynchronized state.
PPPPP	is the PTP preferred master setting, either True or False.
SDOM	is the PTP subdomain, one of DFLT, ALT1, ALT2 or ALT3.
II	is the PTP sync update interval, one of 1,2,8,16, or 64, in seconds.
LL	is the PTP leap second setting, one of 59, 60, or 61, where 59 implies that the last minute of the current day will have 59 seconds (leap second deletion), and 61 implies that the last minute of the current day will have 61 seconds (leap second insertion). On the front-panel display, and in the PTP packets, the leap second setting will show as leap_59 and leap_61.
TMD	is the PTP time epoch either PTP or UTC.
V	is the PTP protocol version, only version 1 is implemented.
TTL	is the PTP multicast TTL, 1-255.

## **PTPv1 Operation**

The Meridian is configured as an IEEE-1588 Grand Master Clock. Verify that the network settings have been configured and tested using **netconfig**. Once the network has been configured the Meridian will begin to transmit PTP Sync messages to the slave clocks.

The PTP sync message and status report from the Meridian is dependent on the status of the clock configuration including the oscillator type and CDMA Subsystem.

The PTP Port State will report either MASTER or PASSIVE. MASTER is reported when the clock is locked to CDMA and the best master clock algorithm (BMC) designates this clock as the MASTER. The port\_state will report PASSIVE if the clock has never locked to CDMA or if the BMC designates this clock as anything other than the MASTER.

The Sync Identifier will report either GPS, or ATOM. GPS is reported when the system starts and when locked to CDMA. The CDMA timing system defines the time to be GPS time. We call the CDMA timing technology “indirect GPS”. (For more information see *Chapter 1 - CDMA Timing-How It Works.*) Therefore, the Meridian will report the identifier as GPS when it is locked to CDMA. ATOM is only reported when the oscillator type in the Meridian is a Rubidium.



The PTP Stratum will report either 3 or 255. The identifier and the calculated offset to UTC determines the PTP Stratum as shown below:

Identifier	PTP Stratum	Offset to UTC
GPS or ATOM	3	> 100 nanosecs
GPS or ATOM	255	Never locked

The PTP leap\_59 and leap\_61 report either TRUE or FALSE. FALSE is reported when no leap insertion or deletion is pending. The leap\_61 reports TRUE on the day of a leap second insertion. The leap\_59 is TRUE on the day of a leap second deletion.

The PTP Time Mode is user configured, either UTC or PTP. When UTC Time Mode is configured the clock transmits the UTC epoch. When the Time Mode is PTP the clock transmits the PTP epoch (TAI). See *About the PTP Second and UTC Time* below for more information.

The PTP Multicast TTL value is factory set to the IEEE-1588 standard that defines TTL=1. The TTL value may be set to any value from 1-255. When set to any value other than 1, you must also configure the PTP Slave accordingly.

## About the PTP Second and UTC Time

The PTP Time Mode selections are PTP and UTC. The IEEE-1588 standard defines the PTP epoch beginning at 0 hours on 1 January 1970. The time measured since this epoch is designated in the standard as PTP seconds. The PTP second is monotonic so does not include leap seconds.

Unlike PTP, the UTC second is not monotonic, that is, from time-to-time there will be leap second insertions. The last second of a leap day is 23:59:60 making the day one second longer than a normal day ending at 23:59:59.

### PTP Second

When the PTP time mode is set to PTP, the slave clocks must utilize the current leap second and leap second pending flags (leap\_59 or leap\_61) to convert the PTP second to UTC.

### UTC Time

When the PTP time mode is set to UTC, then there will be a one second jump in time when a leap second insertion occurs. If the PTP slave does not account for this, it will also jump. Avoid this by using PTP time mode.



# Appendix L

## Specifications

### CDMA Receiver:

Cellular Mobile Receive Band – 869-894 MHz (Standard)  
 North American PCS Mobile Receive Band – 1930-1990 MHz (Standard)  
 Japanese Cellular Mobile Receive Band – 832-870 MHz (Optional Configuration)  
 TIA/EIA IS-95 CDMA Pilot and Sync channels.

### Antenna:

TNC jack on rear panel,  $Z_{in} = 50\Omega$ .  
 Dual Band, 824-896 MHz/1850-1990 MHz,  
 magnetic-base monopole with integral 12 ft. RG-58/U cable and TNC plug.  
 Extension cables and low noise pre-amplifiers are available as options.

### Local Oscillator:

TCXO is standard ( $2.5 \times 10^{-6}$  over  $-20^{\circ}$  to  $70^{\circ}$  C).  
 Options: Medium-Stability OCXO (MS-OCXO) ( $4 \times 10^{-9}$  over  $0^{\circ}$  to  $70^{\circ}$  C).  
 High-Stability OCXO (HS-OCXO) ( $1 \times 10^{-9}$  over  $0^{\circ}$  to  $70^{\circ}$  C).  
 Ultra-Stable OCXO (US-OCXO) ( $5 \times 10^{-10}$  over  $0^{\circ}$  to  $70^{\circ}$  C).  
 Rubidium (Rb) ( $1 \times 10^{-9}$  over  $-20^{\circ}$  to  $70^{\circ}$  C).  
 Rubidium (HS-Rb) ( $1 \times 10^{-10}$  over  $-20^{\circ}$  to  $70^{\circ}$  C).  
 NTP Stratum 1 Holdover Performance: 24 Hours - TCXO  
 35 Days - MS-OCXO  
 35 Days - HS-OCXO  
 35 Days - US-OCXO  
 140 Days - Rb  
 400 Days - HS-Rb

### Time to Lock:

< 5 minutes, typical (TCXO).  
 < 10 minutes, typical (OCXO/Rb).

### Alphanumeric Display/Keypad:

Display: Brilliant 16x280 dot-matrix vacuum-fluorescent.  
 Keypad: Enter, Back, Edit, Right, Left, Up, Down, Help.

### Network I/O:

Rear panel RJ-45 jack  
 AMD PC-Net Fast III 10/100Base-T ethernet

### System Status Indicator:

Sync LED: Green LED pulses to indicate CDMA lock status.  
 Network LED: Amber LED indicates network activity.  
 Alarm LED: Red LED indicates a serious fault condition.

**1 PPS Output:**

Signal: Positive TTL pulse into 50Ω.

User-Selectable Width: 20 us, 1 ms, 100 ms, 500 ms.

User Calibration: +/- 500 us, 1 ns resolution.

Accuracy: <10 microseconds to UTC when locked (typical).

Alignment: Within 10 ns of the other TTL outputs in this unit (except the optional DDS).

Stability: TDEV < 50 ns,  $\tau < 10^4$  seconds.

Rise Time: < 2 nanoseconds.

Connector: Rear-panel BNC jack labeled "1PPS".

Note: To change the pulse width refer to the *Option I/O Menu* in *Chapter 3 - Front-Panel Keypad and Display* or the `cpuopts` and `cpuoptsconfig` commands in *Chapter 4 - Control and Status Commands*.

**AM Code Output:**

Signal: Amplitude-modulated (AM), 3:1 ratio, 1 kHz carrier.

Drive: 1 Vrms into 50Ω.

User-Selectable Formats: IRIG-B120 (IEEE-1344), IRIG-B122, IRIG-B123, NASA-36, or 2137.

Connector: Rear-panel BNC jack labeled "AM CODE".

Note: To change the time code format refer to the *Option I/O Menu* in *Chapter 3 - Front-Panel Keypad and Display* or the `cpuopts` and `cpuoptsconfig` commands in *Chapter 4 - Control and Status Commands*. Also see *Appendix G - Time Code Formats*.

**NTP Synchronization Accuracy:**

NTP Timestamp Accuracy: <10 microseconds @ 200 packets/second (200,000 clients).

NTP Client Synchronization Accuracy: Network factors can limit LAN synchronization accuracy to 1/2 to 2 milliseconds, typical.

Note: To set up the NTP Server refer to *Chapter 5 - Setting Up the NTP Server*.

**Maintenance Console:**

Signal: I/O port at RS-232 levels for secure, local terminal access.

Parameters: 19200 baud, 8 data bits, no parity, 1 stop bit.

Connector: Rear-panel DB-9M connector labeled "RS-232". Pinout is shown below.

Note: For operational details see *Chapter 4 - Control and Status Commands*.

Meridian DB9M Pin	Signal Name
1	Not Connected
2	Receive Data (RX)
3	Transmit Data (TX)
4	Data Terminal Ready (DTR)
5	Ground
6	Data Set Ready (DSR)
7	Request To Send (RTS)
8	Clear To Send (RTS)
9	Not Connected

---

## SPECIFICATIONS

### Supported IPv4 Network Protocols:

SNTP, NTP v2, v3, v4 and broadcast/multicast mode; MD5 authentication and autokey  
SSH server with “secure copy” utility, SCP  
SNMP v1, v2c, v3 with Enterprise MIB  
TIME and DAYTIME server  
TELNET client/server  
FTP client  
DHCP client  
SYSLOG  
HTTP

### Supported IPv6 Network Protocols:

SNTP, NTP v2, v3, v4 and broadcast/multicast mode; MD5 authentication and autokey  
SSH server with “secure copy” utility, SCP  
SNMP v1, v2c, v3 with Enterprise MIB  
TIME and DAYTIME server  
SYSLOG

Note: See *Appendix I - IPv6 Information* for more details.

### Optional PTP/IEEE-1588 Grandmaster:

IEEE-1588-2002 (V1) and IEEE-1588-2008 (V2).  
PTP Timestamp Resolution: 1 microsecond.  
PTP Slave Synchronization Accuracy to the Grandmaster: 10 microseconds, typical,  
network topology dependent.

Note: See *Appendix K - Precision Time Protocol* for more information.

### Power:

90-132 VAC/180-264 VAC, 47-63 Hz, 0.6 A Max. @ 120 VAC, 0.3 A Max. @ 240 VAC  
3-Pin IEC 320 on rear panel, 2 meter line cord is included.

### Size:

Chassis:	1.75”H x 17.0”W x 10.75”D
Antenna:	3.5” Dia. x 2.5” H
Weight:	< 10 lb. (4.50 kg.)

### Environmental:

Operating Temperature:	0° to +50°C
Operating Humidity:	0 to 95%, non-condensing
Storage Temperature:	-40° to +85°C

### DC Power (option):

12 VDC (10-20 VDC), 5A maximum.  
24 VDC (19-36 VDC), 2.5A maximum.  
48 VDC (37-76 VDC), 1.5A maximum.  
125 VDC (70-160 VDC), 0.75A maximum.  
3-position terminal block on rear panel: +DC IN, SAFETY GROUND, -DC IN  
(Floating power input: Either “+” or “-” can be connected to earth ground.)

**Optional Programmable TTL Output (on CPU Module):**

Signal: Positive TTL pulse @ 50Ω on BNC jack.  
 User-Selectable Output Type: On-time pulse rate, a digital time code or synthesized rate output.  
 Pulse Rate: User-selectable to 1, 10, 100, 1K, 10K, 100K, 1M, 5M, 10M PPS, 1PPM, 1PP2S.  
 Duty Cycle: 50% except 1PPS which mimics the standard 1PPS Output.  
 Accuracy:  $< 10^{-11}$  to UTC for 24-hour averaging times when locked.  
 Alignment: Within 10 ns of the other TTL outputs in this unit (except the optional DDS).  
 Stability: See Stability (Allan Deviation) Table below.  
 Synthesized Rate (option): 1 PPS to 10 MPPS in 1PPS steps with DDS Upgrade.  
 Connector: Rear-panel BNC jack labeled “PROG TTL”.  
 Note: To change the output selection refer to the *Option I/O Menu* in *Chapter 3 - Front-Panel Keypad and Display* or the `cpuopts` and `cpuoptsconfig` commands in *Chapter 4 - Control and Status Commands*. Also refer to *Chapter 6 - Optional Rear-Panel Outputs, Programmable TTL Output*.

**Optional Fixed Pulse Rate Output (on CPU Module):**

Signal: Positive TTL pulse @ 50Ω on BNC jack.  
 Rate: Preset at factory and cannot be changed.  
 Accuracy:  $< 10^{-11}$  to UTC for 24-hour averaging times when locked.  
 Alignment: Within 10 ns of the other TTL outputs in this unit (except the optional DDS).  
 Stability: See Stability (Allan Deviation) Table below.  
 Connector: Rear-panel BNC jack labeled with appropriate rate such as: “10 MPPS”.  
 Note: See *Chapter 6 - Optional Rear-Panel Outputs, Fixed Rate TTL Output* for more information.

**Optional Alarm Output (on CPU Module):**

Alarm: MMBT2222A open collector, grounded emitter. High impedance in alarm state.  
 Voltage: 40 VDC, maximum.  
 Saturation Current: 100 mA, maximum.  
 Connector: Rear-panel BNC jack or terminal strip labeled “ALARM”.  
 Note: See *Chapter 6 - Optional Rear-Panel Outputs, Alarm Output* for more information.

**Optional Serial Time Output (on CPU Module):**

Signal: Output only port at RS-232 or RS-422 levels.  
 Baud Rate: User-selectable to 4800, 9600, 19200 or 57600.  
 Parity: User-Selectable to Odd, Even or None.  
 ASCII Formats: User-Selectable to Sysplex, Truetime, EndRun, EndRunX, NENA or NMEA.  
 Connector (RS-232): Rear-panel DB-9M connector labeled: “SERIAL TIME”.  
 Pinout (RS-232): Pin 3 is Transmit Data. Pin 5 is GND.  
 Connector (RS-422): Rear-panel DB9M connector labeled: “SERIAL TIME (RS-422)”.  
 Pinout (RS-422): Pin 3 is +signal. Pin 6 is -signal. Pin 5 is GND.  
 Note: To change the serial time parameters refer to the *Option I/O Menu* in *Chapter 3 - Front-Panel Keypad and Display* or the `cpuopts` and `cpuoptsconfig` commands in *Chapter 4 - Control and Status Commands*. Also see *Serial Time Output* in *Chapter 6 - Optional Rear-Panel Outputs* for more information.

**Optional 1 PPS (RS-422) Output (on CPU Module):**

Signal: RS-422 levels.

User-Selectable Width: 20 us, 1 ms, 100 ms, 500 ms.

User Calibration: +/- 500 us, 1 ns resolution.

Accuracy: <10 microseconds to UTC when locked (typical).

Alignment: Within 10 ns of the TTL outputs in this unit (except the optional DDS).

Stability: TDEV < 50 ns,  $\tau < 10^4$  seconds.

Connector: Rear-panel BNC jack labeled "1PPS RS-422".

Pinout: Pin 3 is +signal. Pin 6 is -signal. Pin 5 is GND.

Note: To change the pulse width refer to the *Option I/O Menu* in *Chapter 3 - Front-Panel Keypad and Display* or the `cpuopts` and `cpuoptsconfig` commands in *Chapter 4 - Control and Status Commands*. Also refer to *Chapter 6 - Optional Rear-Panel Outputs, 1 PPS (RS-422) Output*.

**Optional Programmable Digital Buffer Module Outputs:**

Quantity: Four outputs.

User-Selectable Output Type: On-time pulse rate, a digital time code or synthesized rate output.

On-Time Pulse Rates:

Drive: TTL into 50 $\Omega$ .

Duty Cycle: 50% except 1PPS which mimics the standard 1PPS Output.

Rate: User selectable to 1, 10, 100, 1K, 10K, 100K, 1M, 5M, 10M PPS, 1PPM, 1PP2S.

Alignment: Within 10 ns of the other TTL outputs in this unit (except the optional DDS).

Stability: See Stability (Allan Deviation) Table below.

Digital Time Code:

Drive: TTL into 50 $\Omega$  (DC level shift).

Format: User-selectable to IRIG-B (002, 003, IEEE-1344 compliant), NASA-36, or 2137.

Alignment: Within 10 ns of the other TTL outputs in this unit (except the optional DDS).

Synthesized Rate (option): 1 PPS to 10 MPPS in 1 PPS steps with DDS Upgrade.

Connector: Rear-panel BNC jack.

Note: See *Chapter 6 - Optional Rear-Panel Outputs, Programmable Digital Buffer Module* for more information.

**Optional Digital Buffer Module Outputs:**

Quantity: Four outputs.

Output Type: Set up at factory based on customer requirements and cannot be changed.

Possible output types are: On-time pulse rate, a digital time code or synthesized rate output.

On-Time Pulse Rates:

Drive: TTL into 50Ω or RS-232 levels (+/- 5V into 3kΩ; Slew Rate: 30 V/us).

Duty Cycle: 50% except 1PPS which mimics the standard 1PPS Output.

Rate: Factory preset to 1, 10, 100, 1K, 10K, 100K, 1M, 5M, or 10M PPS, 1PPM, 1PP2S.

Stability: See Stability (Allan Deviation) Table below.

Alignment (TTL): Within 10 ns of the other TTL outputs in this unit (except the optional DDS).

Alignment (RS-232): The actual realized alignment is a function of the zero-crossing delay as specified above (primarily due to the RS232 slew rate limit) and the actual receiver detection threshold. The alignment of synthesized rate pulses remains fixed following each system initialization, but its relationship to other pulse outputs is non-deterministic. If configured for the 1 PPS output, it can be factory-preset to rising-edge or falling-edge on-time.

Digital Time Code:

Drive: TTL into 50Ω (DC level shift) or RS-232 levels.

Format: User-selectable, IRIG-B (002, 003, IEEE-1344 compliant), NASA-36, or 2137.

Alignment (TTL): Within 10 ns of the other TTL outputs in this unit (except the optional DDS).

Alignment (RS-232): See Alignment above.

Synthesized Rate: User-selectable, 1 PPS to 10 MPPS in 1 PPS steps.

Connector (TTL): Rear-panel BNC jack.

Connector (RS-232): Rear-panel DB9M.

Pinout (RS-232): Pin 1 is Output A, Pin 2 is Output B, Pin 3 is Output C, Pin 4 is Output D.

Note: See *Chapter 6 - Optional Rear-Panel Outputs, Digital Buffer Module* for more information.

**Optional Analog Time Code Buffer Module Outputs:**

Quantity: Four outputs.

Drive: 1 Vrms into 50Ω.

Frequency: 1 kHz.

User-Selectable Formats: IRIG-B (122, 123, IEEE-1344 compliant), NASA-36, and 2137.

Connector: Rear-panel BNC jack.

Note: See *Chapter 6 - Optional Rear-Panel Outputs, Analog Time Code Buffer Module* for more information.

**Optional Sine Wave Module Outputs:**

Quantity: 4 (uses one slot) or 8, 12, 16 or 20 (requires additional slots).

Output Frequency: 1 MHz, 5 MHz or 10 MHz.

Output Level: +13 dBm, +/- 2 dBm at 50Ω.

Connector: Rear-panel BNC jack.

Note: See *Chapter 6 - Optional Rear-Panel Outputs, Sine Wave Output Module* for more information.



## SPECIFICATIONS

### Optional Low Phase Noise Module Outputs:

Quantity: 4 (uses one slot) or 8, 12, 16 or 20 (requires additional slots).

Output Frequency: 5 MHz or 10 MHz.

Output Level: +13 dBm, +/- 2 dBm at 50Ω.

Harmonics: < -45 dBc at 50Ω.

Channel-to-Channel Isolation: > +75 dB

Stability: See Stability (Allan Deviation) Table below.

Connector: Rear-panel BNC jack.

Note: See **Chapter 6 - Optional Rear-Panel Outputs, Oscillator/Low Phase Noise Module** for more information.

Phase Noise dBc/Hz @ 10 MHz:

<i>Hz</i>	<i>TCXO</i>	<i>Spurs</i>			
1	-70	-100			
10	-100	-100			
100	-125	-100			
1 k	-135	-100			
10 k	-140	-100			
100 k	-145	-120			
<i>Hz</i>	<i>MS-OCXO</i>	<i>HS-OCXO</i>	<i>US-OCXO</i>	<i>Rb/HS-Rb</i>	<i>Spurs</i>
1	-95	-105	-110	-80	
10	-120	-130	-135	-100	-120
100	-135	-140	-145	-135	-115
1 k	-145	-150	-150	-145	-125
10 k	-145	-150	-150	-145	-125
100 k	-145	-150	-150	-145	-110

### Stability (Allan Deviation) Table:

(Does NOT pertain to the Synthesized Rates (Optional DDS Outputs).)

<i>Tau in Seconds</i>	<i>TCXO Cellular</i>	<i>TCXO PCS</i>	<i>MS-OCXO Cellular</i>	<i>MS-OCXO PCS</i>
1	$1 \times 10^{-9}$	$1 \times 10^{-9}$	$7 \times 10^{-12}$	$7 \times 10^{-12}$
10	$1 \times 10^{-9}$	$1 \times 10^{-9}$	$1 \times 10^{-11}$	$2 \times 10^{-11}$
100	$3 \times 10^{-10}$	$5 \times 10^{-10}$	$3 \times 10^{-11}$	$1 \times 10^{-10}$
1000	$3 \times 10^{-11}$	$5 \times 10^{-11}$	$1 \times 10^{-11}$	$2 \times 10^{-11}$
10000	$9 \times 10^{-12}$	$1 \times 10^{-11}$	$7 \times 10^{-12}$	$8 \times 10^{-12}$
100000	$3 \times 10^{-12}$	$3 \times 10^{-12}$	$3 \times 10^{-12}$	$3 \times 10^{-12}$

**Optional Telecom Clock Module Outputs:**

See *Chapter 6 - Optional Rear-Panel Outputs* for more information.

**COMPOSITE CLOCK**

Quantity: 0, 1 or 2.

Type: Transformer-coupled complementary-pair via 2xRJ48C. Single-ended via 2xBNC.

Frequency: 64 kbps.

Synchronization: Phase locked to the Meridian 10 MHz.

Data Format: All ones. User-selectable bipolar violation (BPV).

Line Z: 110 $\Omega$  nominal (complementary pair), or 75 $\Omega$  nominal (single-ended).

Pulse Shape: Conforms to ITU-T G.703.

Pulse Amplitude: 3.4V pk into 133 $\Omega$ , 3.0V pk into 110 $\Omega$ , 2.4V pk into 75 $\Omega$ .

MTIE/Jitter/Wander: Conforms to ITU-T G.823.

Line Code: Bipolar Return To Zero, Alternate Mark Inversion (AMI), 5/8 Duty Cycle.

User-selectable for 64kcc AMI with no BPV, 64kcc AMI with 8 kHz BPV,  
or 64kcc with 8 kHz BPV and missing BPV at 400 Hz.

Alarm Code: User-selectable for BPV off (AIS) at Major (Blue) Alarm, or BPV always on.

All zeros (LoS) at Critical (Red) Alarm.

Connector: RJ-45 style modular jack (RJ48C-compatible), 1 per output,  
or BNC (single-ended) or DB9M.

RJ48C Pinout: Pin 4 is Clock Out Ring (-). Pin 5 is Clock Out Tip (+).

DB9M Pinout: Pins 1, 5, 7 and 8 are Ground. Pin 2 is Clock Out Ring A (-). Pin 3 is No Connect.

Pin 4 is Clock Out Ring B (-). Pin 6 is Clock Out Tip A (+). Pin 9 is Clock Out Tip B (+).

**E1 CLOCK OUTPUT**

Quantity: 0, 1 or 2.

Type: Transformer-coupled complementary-pair via 2xRJ48c or 1xDB9M. Single-ended via 2xBNC.

Frequency: 2.048 Mbps.

Synchronization: Phase locked to the Meridian 10 MHz.

Data Format: All ones. User-selectable for Unframed, Double-frame or CRC4 Multi-frame.

Line Z: 120 $\Omega$  nominal (complementary pair), or 75 $\Omega$  nominal (single-ended).

Pulse Shape: Conforms to ITU-T G.703.

Pulse Amplitude: 3.0V pk into 120 $\Omega$ , 2.2V pk into 75 $\Omega$ .

MTIE/Jitter/Wander: Conforms to ITU-T G.823.

Line Code: Bipolar Return To Zero, Alternate Mark Inversion (AMI)

(Identical to HDB3 for all ones data.)

Alarm Code: User-selectable for Alarm Indication Signal (AIS),

or Status Sync Messaging (SSM) on Sa4 through Sa8, or none at Major (Blue) Alarm.

All zeros (LoS) at Critical (Red) Alarm.

Connector: RJ-45 style modular jack (RJ48C-compatible), 1 per output,  
or BNC (single-ended) or DB9M.

RJ48C Pinout: Pin 4 is Clock Out Ring (-). Pin 5 is Clock Out Tip (+).

DB9M Pinout: Pins 1, 5, 7 and 8 are Ground. Pin 2 is Clock Out Ring A (-). Pin 3 is No Connect.

Pin 4 is Clock Out Ring B (-). Pin 6 is Clock Out Tip A (+). Pin 9 is Clock Out Tip B (+).

**T1 CLOCK OUTPUT**

Quantity: 0, 1 or 2.

Type: Transformer-coupled complementary-pair.

Frequency: 1.544 Mbps.

Synchronization: Phase locked to the Meridian 10 MHz.

Data Format: All ones. User-selectable for Unframed, D4 SuperFrame (SF)

or CRC6 Extended SuperFrame (ESF).

Line Z: 100 $\Omega$  nominal.

---

## SPECIFICATIONS

Pulse Shape: Conforms to ITU-T G.703.

Pulse Amplitude: 3.0V pk.

MTIE/Jitter/Wander: Conforms to ANSI T1 101 and ITU-T G.824.

Line Build-Out: User-selectable for short haul (DSX-1 0-655 ft.

Line Code: Bipolar Return To Zero, Alternate Mark Inversion (AMI)  
(Identical to B8ZS or PDE with all ones data.)

Alarm Code: User-selectable for Alarm Indication Signal (AIS),  
or Status Sync Messaging (SSM), or none at Major (Blue) Alarm.  
All zeros (LoS) at Critical (Red) Alarm.

Connector: RJ-45 style modular jack (RJ48C-compatible), 1 per output, or DB9M.

RJ48C Pinout: Pin 4 is Clock Out Ring (-). Pin 5 is Clock Out Tip (+).

DB9M Pinout: Pins 1, 5, 7 and 8 are Ground. Pin 2 is Clock Out Ring A (-). Pin 3 is No Connect.  
Pin 4 is Clock Out Ring B (-). Pin 6 is Clock Out Tip A (+). Pin 9 is Clock Out Tip B (+).

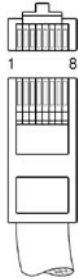

### ALARM RELAY OUTPUTS

Quantity: 0 or 3.

Type: Form C.

Rating: 750 mA @ 42VAC/60VDC.

NC Contact: Closed for alarm-active condition.

NO Contact: Closed for alarm-inactive condition.

Minor Alarm: Active at minor clock faults.

Major Alarm: Active at major clock fault (Blue Alarm).

Critical Alarm: Active at clock operational fault (Red Alarm).

Connector: DB9 Female.

Pinout:	1	Minor NC
	2	Minor NO
	3	Major COM
	4	Critical NC
	5	Critical NO
	6	Minor COM
	7	Major NC
	8	Major NO
	9	Critical COM

**CE/FCC Compliance:** R&TTE Directive 99/5/EEC  
Low Voltage Directive 73/23/EEC  
EMC Directive 89/336/EEC  
With Amendment 93/68/EEC

**Supplementary Compliance Data:**

- **Safety:** EN 60950:2000 (3rd Edition)
- **EMC:** EN55022:1998 Class A, VCCI (April 2004) Class A,  
FCC Part 15 Subpart B Class A, ICES-003 Class A,  
EN 50024:1998 w/ A1:2001 and A2:2003,  
EN61000-3-2:2000, EN61000-3-3:1995 w/ A1:2001



End Run  
TECHNOLOGIES

**DECLARATION OF CONFORMITY**

(According to ISO/IEC GUIDE 22 and EN 45014)

Manufacturer's Name: **EndRun Technologies**

Manufacturer's Address: **1360 North Dutton Avenue #200,  
Santa Rosa, CA 95401**

***DECLARES, THAT THE PRODUCT***

Product Name: **Precision GPS Time Base**

Model Number: **Meridian**

***CONFORMS TO THE FOLLOWING EUROPEAN DIRECTIVES***

***R&TTE Directive 99 / 5 / EEC  
Low Voltage Directive 73 / 23 / EEC  
EMC Directive 89 / 336 / EEC  
With Amendment 93 / 68 / EEC***

Supplementary Information:

Safety : **EN 60950:2000 (3<sup>d</sup> Edition)**  
EMC: **EN 55022:1998, Class A; VCCI (April 2004) Class A  
FCC Part 15 Subpart B Class A; ICES-003 Class A  
EN 55024:1998,(w/A1:2001 & A2:2003  
EN 61000-3-2:2000; EN 61000-3-3:1995 w/A1:2001**

Year Mark First Applied: **2005**

I, the undersigned, hereby declare that the equipment specified above conforms to the above Directives and Standards.

Place: Santa Rosa, CA USA

Signature: 

Date: March 31, 2005

Full Name: David J. Lobsinger

Position: V.P. Hardware Engineering



# Special Modifications

---

## *Changes for Customer Requirements*

*From time to time EndRun Technologies will customize the standard Meridian CDMA Frequency Reference for special customer requirements. If your unit has been modified then this section will describe what those changes are.*

**This section is blank.**







**EndRun**  
**TECHNOLOGIES**

*"Smarter Timing Solutions"*

2270 Northpoint Parkway  
Santa Rosa, CA 95407  
TEL 1-877-749-3878  
FAX 707-573-8619  
[www.endruntechnologies.com](http://www.endruntechnologies.com)

